

OPERATING TOOLS

Powerful, safe, durable: ratchets and sockets from GEDORE are made to meet the highest demands for long-term use. Whether in heavy industry or precision mechanics, GEDORE tools are at home wherever precision, safety and reliability are required.

In industry and DIY, the hand-operated loosening and tightening of various screw connections is part of everyday life. With its comprehensive range of tools, GEDORE offers a wide range of ratchets and sockets for a huge variety of uses and applications. Over 100 years of manufacturing expertise are reflected in GEDORE's intelligently constructed and designed ratchets. Thanks to the careful selection of materials, advanced manufacturing processes and stringent quality management, all ratchets are extremely robust, durable and precise. Ergonomic designs and hand-flattering surfaces ensure that provide relief for the user, even during hard even in tough continuous use.

The broad portfolio of sockets includes solutions for every requirement - from classic sockets to intelligent solutions for power screwdriver sockets to specially developed intelligent profiles. A wide variety of combinations with extensions and articulated pieces enable the optimised use of tools without loss of torque, e.g. for very deep-seated screws or threaded connections.



IT'S THE MECHANICS

- The pawl only engages 100% with the ratchet wheel when it is fully loaded.
- Ratchets work with perfect concentricity
- No unnecessary load on the components
- mechanism does not jam - even under high loads
- A big plus in terms of efficiency and safety at work





DURABLE VERSATILE

HUGE RANGE IN FORM AND FUNCTION

- GEDORE actuating tools and accessories for professional use in every industry.
- For tough continuous use and safety in everyday working life
- Available individually or in practical sets

THE GEDORE "NUT"

- Optimum power transmission and low wear
- Pronounced ball catching groove provides a secure grip on the square drive end
- Deep knurling ensures good grip even with oily hands or when working with protective gloves

GEDORE PREMIUM RATCHETS

- 2-component handle
- Slim and ergonomic design
- Robust and fine-tuned, durable and resilient
- High-grade industrial quality for the toughest continuous use
- Intelligently constructed and designed ratchets meet all demands

i U-20 RATCHETS

Design-oriented premium ratchets



- 1** The release head simplifies attachment and removal of sockets. A ball locking device ensures a tight connection when the ratchet is in use.
- 2** Slim, ergonomic design
- 3** Easy change lever for clockwise and anti-clockwise movement.
- 4** The shaft is made from high-grade chrome-vanadium steel, making it ideal for heavy and constant use.
- 5** 2-component handle, comprising a hard plastic core with rubber sheathing for heavy industrial use. Hanging hole for easy-to-find storage.

2093 U-20
Reversible ratchet 1/4"



6.3 1/4"

- > Acc. to DIN 3122, ISO 3315
- > Fine-toothed (40 teeth), with lever change and push-button release
- > Return angle 9°

> For hand-operated sockets and accessories with square drive as per DIN 3120 - C 6.3, ISO 1174, ball locking device

Code	No.	"		°	mm	mm	
1703749	2093 U-20	1/4"	6,3	9	127	20	0,095

2093 U-10
Reversible ratchet 1/4"

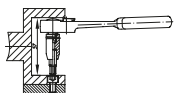

6.3 1/4"

- > Acc. to DIN 3122, ISO 3315
- > With recessed lever change, locks in middle position
- > Return angle 15°
- > For hand-operated sockets and accessories with

square drive as per DIN 3120 - C 6.3, ISO 1174, ball locking device

Code	No.	"		°	mm	mm	
6180470	2093 U-10	1/4"	6,3	15	129	21,5	0,109

2093 U-3
Reversible ratchet 1/4"



6.3 1/4"

- > Acc. to DIN 3122, ISO 3315
- > With non-slip metal disc change, fine-toothed (72 teeth) and robust
- > Return angle 5°

- > For hand-operated sockets and accessories with square drive as per DIN 3120 - C 6.3, ISO 1174, ball locking device

Code	No.	"		°	mm	mm	
6170590	2093 U-3	1/4"	6,3	5	129	25	0,095

2093 Z-94
Ratchet handle 1/4"



6.3 1/4"

- > Acc. to DIN 3122, ISO 3315
- > With square coupler, medium-fine toothed, extremely rugged
- > Return angle 18°

- > For hand-operated sockets and accessories with square drive as per DIN 3120 - C 6.3, ISO 1174, ball locking device

Code	No.	"		°	mm	mm	
6170750	2093 Z-94	1/4"	6,3	18	129	12	0,076

2093 U-3 T
Ratchet with T-handle 1/4"



6.3 1/4"

- > Especially suitable for work in confined spaces
- > Return angle 5°

- > For hand-operated sockets and accessories with square drive as per DIN 3120 - C 6.3, ISO 1174, ball locking device

Code	No.	"		°	mm		
1791532	2093 U-3 T	1/4"	6,3	5	140		0,065

20 (MM)
Socket 1/4"
hexagon

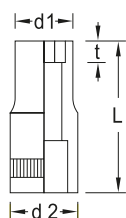

6.3 1/4"

- > Acc. to DIN 3124, ISO 2725-1
- > Square drive as per DIN 3120 - C 6.3, ISO 1174, with ball retention groove
- > Hand-operated

Code	No.	mm	L	d1	d2	t	
6165400	20 4	4	25	6,9	12,0	2,0	0,012
6165590	20 4,5	4,5	25	7,5	12,0	2,3	0,013
6165670	20 5	5	25	8,2	12,0	2,5	0,01
6165750	20 5,5	5,5	25	8,8	12,0	3,0	0,01
6165830	20 6	6	25	9,4	12,0	3,5	0,01
6165910	20 7	7	25	11,0	12,0	4,0	0,011
6166050	20 8	8	25	12,0	12,0	5,0	0,014
6166130	20 9	9	25	13,0	13,0	5,0	0,016
6166210	20 10	10	25	14,7	14,7	6,0	0,018
6166480	20 11	11	25	16,0	16,0	7,0	0,025
6166560	20 12	12	25	17,0	17,0	8,0	0,029
6166640	20 13	13	25	18,5	18,5	8,0	0,03
6166720	20 14	14	25	19,7	19,7	10,0	0,18

20 (AF)
Socket 1/4"
hexagon

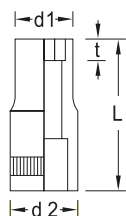

6,3 1/4"

- > Square drive as per DIN 3120 - C 6.3, ISO 1174, with ball retention groove
- > Hand-operated

Code	No.	AF	L	d1	d2	t	kg
6167020	20 3/16AF	3/16"	25	7,8	12,0	2,5	0,009
6167100	20 7/32AF	7/32"	25	8,8	12,0	3,0	0,009
6167290	20 1/4AF	1/4"	25	9,8	12,0	3,5	0,025
6167370	20 9/32AF	9/32"	25	11,0	12,0	4,0	0,01
6167450	20 5/16AF	5/16"	25	12,0	12,0	5,0	0,013
6167530	20 11/32AF	11/32"	25	13,0	13,0	5,0	0,015
6167610	20 3/8AF	3/8"	25	14,0	6,0	6,0	0,018
6167880	20 7/16AF	7/16"	25	16,0	16,0	7,0	0,023
6167960	20 1/2AF	1/2"	25	18,0	18,0	8,0	0,029
6161840	20 9/16AF	9/16"	25	20,0	20,0	10,0	0,036

20 L (MM)
Socket 1/4"
hexagon,
long pattern

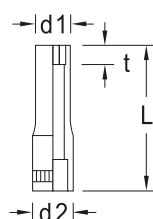

6,3 1/4"

- > Acc. to DIN 3124, ISO 2725-1
- > Square drive as per DIN 3120 - C 6.3, ISO 1174, with ball retention groove
- > Hand-operated

Code	No.	mm	L	d1	d2	t	kg
6191400	20 L 4	4	50	6,7	12,0	3,0	0,028
6191590	20 L 4,5	4,5	50	7,2	12,0	3,4	0,026
6191670	20 L 5	5	50	7,8	12,0	3,7	0,03
6191750	20 L 5,5	5,5	50	8,5	12,0	4,5	0,03
6191830	20 L 6	6	50	9,1	12,0	5,2	0,029
6191910	20 L 7	7	50	10,5	12,0	6,0	0,025
6192050	20 L 8	8	50	11,3	12,0	7,5	0,024
6192130	20 L 9	9	50	12,0	13,2	7,5	0,032
6192210	20 L 10	10	50	12,7	14,7	9,0	0,039
6192480	20 L 11	11	50	14,0	16,0	10,5	0,05
6192560	20 L 12	12	50	15,0	17,0	12,0	0,055
6192640	20 L 13	13	50	16,0	18,0	12,0	0,055

20 L (AF)
Socket 1/4" hex,
long hexagon,
long pattern

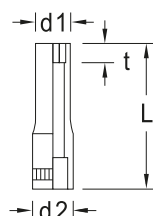

6,3 1/4"

- > Square drive as per DIN 3120 - C 6.3, ISO 1174, with ball retention groove
- > Hand-operated

Code	No.	AF	L	d1	d2	t	kg
6192800	20 L 3/16AF	3/16"	50	7,8	12,0	3,7	0,016
6192990	20 L 7/32AF	7/32"	50	8,8	12,0	4,5	0,017
6193020	20 L 1/4AF	1/4"	50	9,8	12,0	5,2	0,017
6193100	20 L 9/32AF	9/32"	50	11,0	12,0	6,0	0,022
6193290	20 L 5/16AF	5/16"	50	12,0	12,0	7,5	0,025
6193370	20 L 11/32AF	11/32"	50	13,0	13,0	7,5	0,029
6193450	20 L 3/8AF	3/8"	50	14,0	14,0	9,0	0,033
6193530	20 L 7/16AF	7/16"	50	16,0	16,0	10,5	0,043
6193610	20 L 1/2AF	1/2"	50	18,0	18,0	12,0	0,054

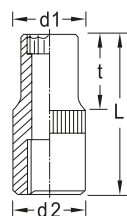
D 20 (MM)Socket 1/4"
Bi-hexagon
UD profile**6,3** **1/4"**

- > Acc. to DIN 3124, ISO 2725-1
- > Square drive as per DIN 3120 - C 6.3, ISO 1174, with ball retention groove
- > Hand-operated

Code	No.		L	d1	d2	t	
1649558	D 20 4	4	25	6,7	12,0	2,0	0,009
1649566	D 20 4,5	4,5	25	7,2	12,0	2,3	0,008
1649574	D 20 5	5	25	7,8	12,0	2,5	0,011
1802402	D 20 5,5	5,5	25	8,5	12,0	3,0	0,012
1649582	D 20 6	6	25	9,1	12,0	3,5	0,01
1649590	D 20 7	7	25	10,5	12,0	4,0	0,013
6225750	D 20 8	8	25	11,3	12,0	5,0	0,013
6225830	D 20 9	9	25	12,0	13,0	5,0	0,015
6226050	D 20 10	10	25	14,5	12,7	6,0	0,02
6226130	D 20 11	11	25	16,0	14,0	7,0	0,024
6226480	D 20 12	12	25	17,0	15,0	8,0	0,026
6226640	D 20 13	13	25	18,0	16,0	8,0	0,029
6226720	D 20 14	14	25	19,7	18,0	10,0	0,036

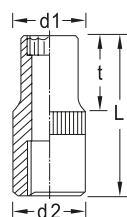
D 20 (AF)Socket 1/4"
Bi-hexagon
UD profile**6,3** **1/4"**

- > Square drive as per DIN 3120 - C 6.3, ISO 1174, with ball retention groove
- > Hand-operated

Code	No.		L	d1	d2	t	
1812505	D 20 3/16AF	3/16"	25	7,6	12,0	2,5	0,01
1812513	D 20 7/32AF	7/32"	25	8,5	12,0	3,0	0,011
1812521	D 20 1/4AF	1/4"	25	9,4	12,0	3,5	0,011
1812548	D 20 9/32AF	9/32"	25	10,6	12,0	4,0	0,012
6226800	D 20 5/16AF	5/16"	25	11,3	12,0	5,0	0,012
6226990	D 20 11/32AF	11/32"	25	12,0	13,0	5,0	0,015
6227020	D 20 3/8AF	3/8"	25	14,0	12,7	6,0	0,017
1901702	D 20 13/32AF	13/32"	25	14,5	12,7	6,0	0,02
6227370	D 20 7/16AF	7/16"	25	16,0	14,0	7,0	0,022
6227450	D 20 1/2AF	1/2"	25	18,0	16,0	8,0	0,028
6228180	D 20 9/16AF	9/16"	25	20,0	20,0	10,0	0,034

D 20 L (AF)Socket 1/4"
Bi-hexagon UD profile,
long pattern**6,3** **1/4"**

- > Square drive as per DIN 3120 - C 6.3, ISO 1174, with ball retention groove
- > Hand-operated

Code	No.		L	d1	d2	t	
1965433	D 20 L 3/16AF	3/16"	50	7,6	12,0	3,7	0,017
1965476	D 20 L 7/32AF	7/32"	50	8,5	12,0	4,5	0,019
1965417	D 20 L 1/4AF	1/4"	50	9,4	12,0	5,2	0,017
1965484	D 20 L 9/32AF	9/32"	50	10,6	12,0	6,0	0,024
1965441	D 20 L 5/16AF	5/16"	50	11,3	12,0	7,5	0,024
1965492	D 20 L 11/32AF	11/32"	50	13,2	12,0	7,5	0,043
1965425	D 20 L 3/8AF	3/8"	50	14,7	12,7	9,0	0,035
1965468	D 20 L 7/16AF	7/16"	50	16,0	14,0	10,5	0,043
1965409	D 20 L 1/2AF	1/2"	50	18,0	16,0	12,0	0,054

WWW.GEDORE.COM

TX 20

Socket 1/4"
for protruding
TX head screws

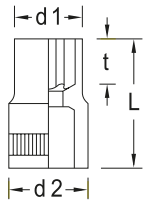

6.3 1/4"

- > Square drive as per DIN 3120 - C 6.3, ISO 1174, with ball retention groove
- > Hand-operated

Code	No.	mm	M	mm	L	d1	d2	t	kg
6187640	TX 20 E5	E5	M4	4,73	25	7,0	12,0	5,0	0,013
6187720	TX 20 E6	E6	M5	5,74	25	8,0	12,0	5,0	0,01
6187800	TX 20 E7	E7	M6	6,16	25	9,5	12,0	6,0	0,011
6187990	TX 20 E8	E8	M6 - M7	7,52	25	10,5	12,0	6,5	0,014
6193880	TX 20 E4	E4	M3	3,86	25	5,5	12,0	4,5	0,008
6193960	TX 20 E10	E10	M8	9,42	25	13,0	13,0	7,0	0,018

ITX 20

Screwdriver
bit socket 1/4"
for recessed TX head
screws

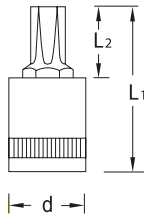

6.3 1/4"

- > Square drive as per DIN 3120 - C 6.3, ISO 1174, with ball retention groove
- > Hand-operated

Code	No.		M	mm	L1	L2	d	kg
6190430	ITX 20 T8	T8	M2,5	2,31	37	15,0	12	0,015
6190510	ITX 20 T9	T9	M3	2,50	37	15,0	12	0,015
6190780	ITX 20 T10	T10	M3 - M3,5	2,74	37	15,0	12	0,015
6190860	ITX 20 T15	T15	M3,5 - M4	3,27	37	15,0	12	0,016
6190940	ITX 20 T20	T20	M4 - M5	3,86	37	15,0	12	0,016
6191080	ITX 20 T25	T25	M4,5 - M5	4,43	37	15,0	12	0,016
6191160	ITX 20 T27	T27	M4,5 - M6	4,99	37	15,0	12	0,016
6191240	ITX 20 T30	T30	M6 - M7	5,52	37	15,0	12	0,016
6265890	ITX 20 T40	T40	M7 - M8	6,65	37	15,0	12	0,017

ITX 20 K

Screwdriver
bit socket 1/4" with
ball end, for recessed
TX head screws

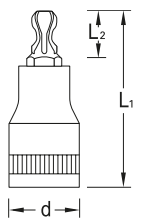

6.3 1/4"

- > Square drive as per DIN 3120 - C 6.3, ISO 1174, with ball retention groove
- > hand operated, knurled for good grip
- > Total swivel angle approx. 15-20°

Code	No.		M	mm	L1	L2	d	kg
6120300	ITX 20 KT15	T15	M3,5 - M4	3,27	37	14,5	12	0,015
6120490	ITX 20 K T20	T20	M4 - M5	3,86	37	14,5	12	0,015
6120570	ITX 20 K T25	T25	M4,5 - M5	4,43	37	14,5	12	0,015
6120650	ITX 20 K T27	T27	M4,5 - M6	4,99	37	14,5	12	0,015
6120730	ITX 20 K T30	T30	M6 - M7	5,52	37	14,5	12	0,015
6120810	ITX 20 K T40	T40	M7 - M8	6,65	37	14,0	14	0,025

IS 20

Screwdriver
bit socket 1/4" for
slotted head screws

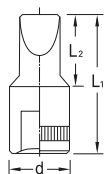

6.3 1/4"

- > Square drive as per DIN 3120 - C 6.3, ISO 1174, with ball retention groove
- > Hand-operated
- > Blade tip acc. to DIN ISO 2380-1 Form B

Code	No.	mm	mm	L1	L2	d	kg
6171560	IS 20 4	4	0,8	28	16,0	12	0,011
6171640	IS 20 5,5	5,5	1,0	28	16,0	12	0,012
6174230	IS 20 6,5	6,5	1,2	28	16,0	12	0,012
6174310	IS 20 8	8	1,6	28	16,0	12	0,012

IKS 20
Screwdriver
bit socket 1/4"

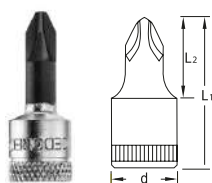

6,3 1/4"

- > Square drive as per DIN 3120 - C 6.3, ISO 1174, with ball retention groove
- > Hand-operated
- > Tip as per DIN ISO 8764-1 PH

Code	No.	⊕ PH	L1	L2	d	
6174580	IKS 20 1	1	28	16,0		0,011
6174660	IKS 20 2	2	28	16,0	12	0,012
6174740	IKS 20 3	3	28	16,0	12	0,012
6174820	IKS 20 4	4	28	16,0	12	0,014

IKS 20 PZD
Screwdriver
bit socket 1/4"
for cross-head screws
Pozi PZ

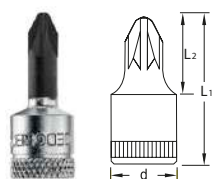

6,3 1/4"

- > Square drive as per DIN 3120 - C 6.3, ISO 1174, with ball retention groove
- > Hand-operated
- > Tip as per DIN ISO 8764-1 PZ

Code	No.	⊕ PZ	L1	L2	d	
6187130	IKS 20 PZD 1	1	28	16,0	12	0,012
6187210	IKS 20 PZD 2	2	28	16,0	12	0,013
6187480	IKS 20 PZD 3	3	28	16,0	12	0,014
6187560	IKS 20 PZD 4	4	28	16,0	12	0,015

IN 20
Screwdriver
bit socket 1/4"
for in-hex screws

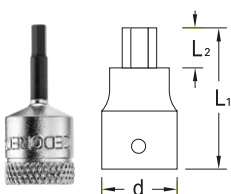

6,3 1/4"

- > Acc. to DIN 7422
- > Square drive as per DIN 3120 - C 6.3, ISO 1174, with ball retention groove
- > Hand-operated
- * not standardised**

Code	No.	mm	L1	L2	d	
1812556*	IN 20 2	2	28	16,0	12	0,01
1707736*	IN 20 2,5	2,5	28	16,0	12	0,01
6176010	IN 20 3	3	28	16,0	12	0,011
6176280	IN 20 4	4	28	16,0	12	0,011
6176360	IN 20 5	5	28	16,0	12	0,012
6178490	IN 20 6	6	28	16,0	12	0,013
6178570*	IN 20 8	8	28	16,0	12	0,016

IN 20 L
Screwdriver
bit socket 1/4"
for in-hex screws,
long pattern

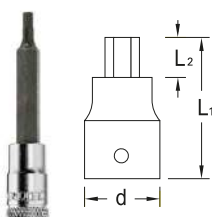

6,3 1/4"

- > Acc. to DIN 7422
- > Square drive as per DIN 3120 - C 6.3, ISO 1174, with ball retention groove
- > Hand-operated

Code	No.	mm	L1	L2	d	
1933256	IN 20 L 3-60	3	60	32,0	12	0,024
1933264	IN 20 L 4-60	4	60	32,0	12	0,025
1933272	IN 20 L 5-60	5	60	32,0	12	0,027
1933280	IN 20 L 6-60	6	60	32,0	12	0,029
1933299	IN 20 L 8-60	8	60	32,0	12	0,05

IN 20 K
Screwdriver
bit socket 1/4"
with ball end,
for in-hex screws

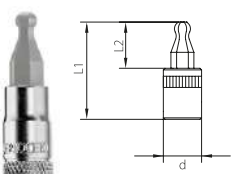

6,3 1/4"

- > Square drive as per DIN 3120 - C 6.3, ISO 1174, with ball retention groove
- > Hand-operated
- > Total swivel angle approx. 15-20°

Code	No.	mm	L1	L2	d	
2219409	IN 20 K 4	4	37	14,5	12	0,01
2219417	IN 20 K 5	5	37	14,5	12	0,01
2219468	IN 20 K 6	6	37	14,5	12	0,013

D 20 DMU-3
Socket set 1/4"
14 pieces



6,3 **1/4"**

- > With hand operated 12-point UD profile sockets and operating tools
- > With fine toothed, dial change ratchet
- > In plastic case

Code	No.	Contents	Pieces	
1815598	D 20 DMU-3	Reversible ratchet 1/4" No. 2093 U-3 Socket wrench insert 1/4" 12-point UD profile No. D 20 4 4.5 5 5.5 6 7 8 9 10 11 12 13 Extension 1/4" No. 2090-4	14	0,429

INS 20 PM
Screwdriver set 1/4"
15 pieces



6,3 **1/4"**

- > With hand operated screwdriver inserts
- > In plastic case

Code	No.	Contents	Pieces	
1815601	INS 20 PM	Screwdriver bit socket 1/4" for hexagon socket screws No. IN 20 3 4 5 6 8 Screwdriver bit socket 1/4" for slotted screws No. IS 20 4 5.5 6.5 8 Screwdriver bit socket 1/4" for cross-head screws PH No. IKS 20 1 2 3 Screwdriver bit socket 1/4" for cross-head screws PZ No. IKS 20 PZD 1 2 3	15	0,285

ITX 20 TX-015
Screwdriver set 1/4"
15 pieces



6,3 **1/4"**

- > With hand operated screwdriver inserts
- > In plastic case

Code	No.	Contents	Pieces	
1815628	ITX 20 TX-015	Screwdriver bit socket 1/4" for recessed TX screws No. ITX 20 T8 T9 T10 T15 T20 T25 T27 T30 T40 Socket wrench insert 1/4" for external TX screws No. TX 20 E4 E5 E6 E7 E8 E10	15	0,307

D 20 EMU-3
Socket set 1/4"
17 pieces



6,3 **1/4"**

- > With hand operated 12-point UD profile sockets
- > With operating tools
- > With fine toothed, dial change ratchet
- > In plastic case

Code	No.	Contents	Pieces	
1815652	D 20 EMU-3	Reversible ratchet 1/4" No. 2093 U-3 Socket wrench insert 1/4" 12-point UD profile No. D 20 4 4.5 5 5.5 6 7 8 9 10 11 13 Cross handle 1/4" No. 2087 Extension 1/4" No. 2090-4 Cardan joint 1/4" No. 2095 Multi-handle 1/4" No. 676	17	0,625

D 20 KMU-20
Socket set 1/4"
37 pieces



6,3 **1/4"**

- > With hand operated 12-point UD profile sockets
- > With operating tools
- > With robust lever-change reversible ratchet, with push-button release
- > In plastic case

Code	No.	Contents	Pieces	
1822373	D 20 KMU-20	Reversible ratchet 1/4" No. 2093 U-20 Socket wrench insert 1/4" 12-point UD profile No. D 20 4 5 6 7 8 9 10 11 12 13 Screwdriver bit 1/4" for slotted screws No. 680 4.5 5 6.5 Screwdriver bit 1/4" for hexagon socket screws No. 685 3 4 5 6 Screwdriver bit 1/4" for multi-tooth socket screws XZN No. 685 X 5 6 8 Screwdriver bit 1/4" for multi-tooth socket head screws XZN No. 687 TX T10 T15 T20 T25 T27 T30 T40 Screwdriver bit 1/4" for cross-head screws PH No. 690 1 2 Screwdriver bit 1/4" for cross-head screws PZ No. 690 PZD 1 2 3 Extension 1/4" No. 2090-4 Bit adapter 1/4" No. 620 Multi-handle 1/4" No. 676 Bit holder for machine screwdriver No. 699	37	0,712

D 20 KAU-20Socket set 1/4"
37 pieces**6.3** **1/4"**

- > With hand operated 12-point UD profile sockets
- > With operating tools
- > With robust lever-change reversible ratchet, with push-button release
- > In plastic case

Code	No.	Contents	Pieces	
2010348	D 20 KAU-20	Reversible ratchet 1/4" No. 2093 U-20 Socket wrench insert 1/4" 12-point UD profile No. D 20 4 5 6 7 8 9 10 11 12 13 Screwdriver bit 1/4" for slotted screws No. 680 4 5.5 6.5 Screwdriver bit 1/4" for hexagon socket screws No. 685 3 4 5 6 Screwdriver bit 1/4" for multi-tooth socket screws XZN No. 685 X 5 6 8 Screwdriver bit 1/4" for multi-tooth socket head screws XZN No. 687 TX T10 T15 T20 T25 T27 T30 T40 Screwdriver bit 1/4" for cross-head screws PH No. 690 1 2 Screwdriver bit 1/4" for cross-head screws PZ No. 690 PZD 1 2 3 Extension 1/4" No. 2090-4 Bit adapter 1/4" No. 620 Multi-handle 1/4" No. 676 Bit holder for machine screwdriver No. 699	37	0,656

D 20 TMU-10Socket set 1/4"
40 pieces**6.3** **1/4"**

- > With hand operated 12-point UD profile sockets
- > With operating tools
- > With robust lever-change reversible ratchet
- > In plastic case

Code	No.	Contents	Pieces	
1815660	D 20 TMU-10	Reversible ratchet 1/4" No. 2093 U-10 Socket wrench insert 1/4" 12-point UD profile No. D 20 4 5 6 7 8 9 10 11 12 13 Screwdriver bit 1/4" for slotted screws No. 680 4 6.5 Screwdriver bit 1/4" for hexagon socket screws No. 685 3 4 5 6 8 Screwdriver bit 1/4" for multi-tooth socket screws XZN No. 685 X 5 6 8 Screwdriver bit 1/4" for multi-tooth socket head screws XZN No. 687 TX T10 T15 T20 T25 T27 T30 T40 Screwdriver bit 1/4" for cross-head screws PH No. 690 1 2 Screwdriver bit 1/4" for cross-head screws PZ No. 690 PZD 1 2 3 Extension 1/4" No. 2090-4 Cardan joint No. 2095 Bit adapter 1/4" No. 620 Insert holder No. 673 Multi-handle 1/4" No. 676 Combination holding tool No. 639 Bit holder for machine screwdriver No. 699	40	0,767

D 20 MOTBasic tool set 1/4",
for motorbikes
30 pieces**6.3** **1/4"**

- > Selected tools with metric dimensions for "first aid" on the motorcycle
- > In plastic case

Code	No.	Contents	Pieces	
2190281	D 20 MOT	Cross handle ratchet 1/4" No. 2093 U-3 T Socket wrench insert 1/4" 12-point UD profile No. D 20 8 9 10 11 12 13 14 Screwdriver bit 1/4" for hexagon socket screws No. 685 3 4 5 6 8 10 Screwdriver bit 1/4" for multi-tooth socket head screws XZN No. 687 TX T10 T15 T20 T25 T27 T30 T40 Screwdriver bit 1/4" for cross-head screws PH No. 690 1 2 3 Screwdriver bit 1/4" for slotted screws No. 680 4 6.5 Cardan extension 1/4" No. KR-4 Extension 1/4" No. 2090-6 Cardan joint 1/4" No. 2095 Bit adapter 1/4" No. 620	30	0,572

20 LMU-10
Socket set 1/4"
49 pieces

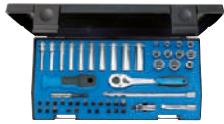

6,3 **1/4"**

- > With long hexagonal and short 12-point UD-profile sockets, hand operated
- > With operating tools
- > In plastic case

Code	No.	Contents	Pieces	
1815687	20 LMU-10	Reversible ratchet 1/4" No. 2093 U-10 Socket wrench insert 1/4" 12-point UD profile No. D 20 4 5 6 7 8 9 10 11 12 13 Socket wrench insert 1/4" hexagon, long No. 20 L 4 4.5 5 6 7 8 9 10 12 13 Screwdriver bit 1/4" for slotted screws No. 680 4 6 5 Screwdriver bit 1/4" for hexagon socket screws No. 685 3 4 5 6 8 Screwdriver bit 1/4" for multi-tooth socket screws XZN No. 685 X 5 6 8 Screwdriver bit 1/4" for multi-tooth socket head screws XZN No. 687 TX T10 T15 T20 T25 T27 T30 T40 Screwdriver bit 1/4" for cross-head screws PH No. 690 1 2 Screwdriver bit 1/4" for cross-head screws PZ No. 690 PZD 1 2 3 Bit adapter 1/4" No. 620 Multi-handle 1/4" No. 676 Extension 1/4" No. 2090-2 -6 Cardan joint 1/4" No. 2095 Bit holder for machine screwdriver No. 699	49	1,262

20 EM
Socket set 1/4"
16 pieces



6,3 **1/4"**

- > With hand-operated hexagon sockets
- > With operating tools
- > With fine toothed, dial change ratchet
- > With robust lever-change reversible ratchet
- > In plastic case

Code	No.	Contents	Pieces	
6172290	20 EMU-3	Reversible ratchet 1/4" No. 2093 U-3 Socket wrench insert 1/4" hexagon No. 20 4 4.5 5 5.5 6 7 8 9 10 11 12 13 14 Cross handle 1/4" No. 2087 Extension 1/4" No. 2090-4 Cardan joint 1/4" No. 2095 Square plug-in handle 1/4" No. 2098	16	0,776
6162220	20 EMU-10	Reversible ratchet 1/4" No. 2093 U-10 Socket wrench insert 1/4" hexagon No. 20 4 4.5 5 5.5 6 7 8 9 10 11 13 Cross handle 1/4" No. 2087 Extension 1/4" No. 2090-4 Cardan joint 1/4" No. 2095 Square plug-in handle 1/4" No. 2098	16	0,79

20 IMU-3
Socket set 1/4"
32 pieces



6,3 **1/4"**

- > With hand-operated hexagon sockets
- > With operating tools
- > With fine toothed, dial change ratchet
- > In plastic case

Code	No.	Contents	Pieces	
6174150	20 IMU-3	Reversible ratchet 1/4" No. 2093 U-3 Socket wrench insert 1/4" hexagon No.20 4 5 6 7 8 9 10 11 12 13 14 Screwdriver bit socket 1/4" for slotted screws No. IS 20 4 5.5 6.5 8 Screwdriver bit socket 1/4" for hexagon socket screws No. IN 20 3 4 5 6 8 Screwdriver bit socket 1/4" for cross-head screws PH No. IKS 20 1 2 3 Screwdriver bit socket 1/4" for cross-head screws PZ No. IKS 20 PZD 1 2 3 Cross handle 1/4" No. 2087 Extension 1/4" No. 2090-2 -6 Cardan joint 1/4" No. 2095 Square plug-in handle 1/4" No. 2098	32	1,298

20 ITU-3
Socket set 1/4"
36 pieces



6,3 **1/4"**

- > With hand-operated hexagon sockets
- > With operating tools
- > With fine toothed, dial change ratchet
- > In plastic case

Code	No.	Contents	Pieces	
6196710	20 ITU-3	reversible ratchet 1/2" No. U-10 T Reversible ratchet 1/4" No. 2093 U-3 Socket wrench insert 1/4" hexagon No. 20 4 5 6 7 8 9 10 11 12 13 14 Screwdriver bit socket 1/4" for hexagon socket screws No. IN 20 3 4 5 6 8 Socket wrench insert 1/4" for external TRX screws No. TX 20 E4 E5 E6 E7 E8 E10 Screwdriver bit socket 1/4" for recessed TX screws No. ITX 20 T8 T9 T10 T15 T20 T25 T27 T30 Cross handle 1/4" No. 2087 Extension 1/4" No. 2090-2 -6 Cardan joint 1/4" No. 2095 Square plug-in handle 1/4" No. 2098	36	1,376

2098 T
Driving handle 1/4"



- > For hand-operated sockets and accessories with square drive as per DIN 3120, ISO 1174, ball locking device
- > With bit adapter No. 620 also suitable for 1/4" bits
- > Especially suitable for deep-seated screws

Code	No.	"	mm	mm	kg
1939998	2098 T	1/4"	6,3	300	0,15

2098
Driving handle 1/4"



- > Acc. to DIN 3122, ISO 3315
- > For hand-operated sockets and accessories with square drive as per DIN 3120, ISO 1174, ball locking device

Code	No.	"	mm	mm	kg
6171480	2098	1/4"	6,3	140	0,07

2087
Sliding T bar 1/4"



- > Acc. to DIN 3122, ISO 3315
- > For hand-operated sockets and accessories with square drive as per DIN 3120, ISO 1174, ball locking device

Code	No.	"	mm	mm	kg
6170160	2087	1/4"	6,3	115	0,039

2099
Telescopic extension 1/4" magnetic

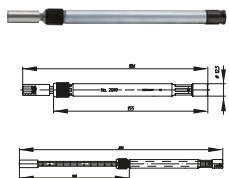

- > With 1/4" female square drive and 1/4" hexagon socket
- > Automatic, positive locking
- > Adjustable in 10 mm steps from 192-296 mm

Code	No.	"	mm	"	mm	mm	kg
1888455	2099	1/4"	6,3	1/4"	6,3	195	0,205

2090
Extension 1/4"



- > Acc. to DIN 3123, ISO 3316
- > For hand-operated sockets and accessories with square drive as per DIN 3120, ISO 1174, ball locking device

Code	No.	"	mm	mm	kg
6170320	2090-2	1/4"	6,3	55	0,025
6170400	2090-4	1/4"	6,3	97	0,041
6171210	2090-6	1/4"	6,3	148	0,061
6173340	2090-12	1/4"	6,3	305	0,124

2088
Flexible extension 1/4"



- > For hand-operated sockets and accessories with square drive as per DIN 3120, ISO 1174, ball locking device

Code	No.	"	mm	mm	kg
6170240	2088	1/4"	6,3	120	0,046

2090 A
Extension 1/4"
with release



- > Easy access to deep-fitting screws in confined areas
- > No unintentional release due to safety ring
- > For hand-operated sockets and accessories with square drive as per DIN 3120, ISO 1174, ball locking device

Code	No.	"	mm	↳ mm	kg
1932284	2090 A-2	1/4"	6,3	55	0,03
1932292	2090 A-4	1/4"	6,3	97	0,05
1932306	2090 A-12	1/4"	6,3	305	0,125

2090 KR
Universal extension 1/4"



- > With ball end
- > For hand-operated sockets and accessories with square drive as per DIN 3120, ISO 1174, ball locking device
- > The extension is able to pivot up to 15°

Code	No.	"	mm	↳ mm	kg
1812564	2090 KR-2	1/4"	6,3	55	0,024
1812572	2090 KR-4	1/4"	6,3	97	0,045
6121030	2090 KR-6	1/4"	6,3	148	0,06

2095
Universal joint 1/4"



- > Acc. to DIN 3123, ISO 3316
- > For hand-operated sockets and accessories with square drive as per DIN 3120, ISO 1174, ball locking device

Code	No.	"	mm	"	mm	↳ mm	kg
6170910	2095	1/4"	6,3	1/4"	6,3	38	0,026

2094
Coupler 1/4"



- > Acc. to DIN 3122, ISO 3315
- > For hand-operated sockets and accessories with square drive as per DIN 3120, ISO 1174, ball locking device

Code	No.	"	mm	↳ mm	kg
6170830	2094	1/4"	6,3	19,8	0,006

2030
Converter
1/4" to 3/8"

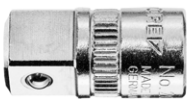

1/4"
6,3 mm

3/8"
10 mm

- > Acc. to DIN 3123, ISO 3316
- > For hand-operated sockets and accessories with square drive as per DIN 3120, ISO 1174, ball locking device

Code	No.	"	mm	"	mm	↳ mm	kg
6170080	2030	1/4"	6,3	3/8"	10	26	0,02

S 2032-05
Adaptor set 1/4" - 3/4"
5 pieces



- > With reducer and enlargement pieces from 1/4" to 3/4"
- > Reducers 1930, 3020
- > Enlargement pieces 2030, 3019, 1932
- > Please observe the maximum load capacities of the outer square edge according to DIN 3123, ISO 3316

Code	No.	Contents	Pieces	kg
1729071	S 2032-05	Converter 2030 1/4" - 3/8" (max. 62 Nm) Converter 3019 3/8" - 1/2" (max. 202 Nm) Converter 1932 1/2" - 3/4" (max. 512 Nm) Reducer 3020 3/8" - 1/4" (max. 62 Nm) Reducer 1930 1/2" - 3/8" (max. 202 Nm)	5	0,34

SL 2013

Tool holding rail,
magnetic 1/4"
empty



6.3 **1/4"**

- > 13 Outer square edge suitable for sockets
Nominal size 6.3 (1/4")
- > 2 inner square adaptors for ratchets, sliding handles, extensions etc.
- > A strong magnet securely holds the socket rail to ferrous metals
- > Delivery without sockets

Code	No.	↳ mm ↳	mm	kg
1761080	SL 2013	380	33	0,355

3093 U-20

Reversible ratchet 3/8"



10 **3/8"**

- > Acc. to DIN 3122, ISO 3315
 - > Fine-toothed (60 teeth), with lever change and push-button release
 - > Return angle 6°
- > For hand-operated sockets and accessories with square drive as per DIN 3120 - C 10, ISO 1174, ball locking device

Code	No.	"	"	°	↳ mm ↳	mm	kg
1556800	3093 U-20	3/8"	10	6	200	29,7	0,292

3093 U-10

Reversible ratchet 3/8"



10 **3/8"**

- > Acc. to DIN 3122, ISO 3315
 - > with push-button release
 - > Return angle 11.25°
- > For hand-operated sockets and accessories with square drive as per DIN 3120 - C 10, ISO 1174, ball locking device

Code	No.	"	"	°	↳ mm ↳	mm	kg
6236950	3093 U-10	3/8"	10	11	200	30,2	0,254

3093 U-3

Reversible ratchet 3/8"



10 **3/8"**

- > Acc. to DIN 3122, ISO 3315
 - > With non-slip metal disc change, fine-toothed (72 teeth) and robust
 - > Return angle 5°
- > For hand-operated sockets and accessories with square drive as per DIN 3120 - C 10, ISO 1174, ball locking device

Code	No.	"	"	°	↳ mm ↳	mm	kg
6237090	3093 U-3	3/8"	10	5	200	33,5	0,244

3093 GU-3

Swivel head reversible ratchet 3/8"



10 **3/8"**

- > 180° swivelling, with joint lock
 - > With non-slip metal disc change, fine-toothed (72 teeth) and robust
 - > Return angle 5°
- > For hand-operated sockets and accessories with square drive as per DIN 3120 - C 10, ISO 1174, ball locking device

Code	No.	"	"	°	↳ mm ↳	mm	kg
6237170	3093 GU-3	3/8"	10	5	282	33,5	0,525

3093 Z-94
Ratchet handle 3/8"



10 3/8"

- > Acc. to DIN 3122, ISO 3315
- > With square coupler, medium-fine toothed, extremely rugged
- > Return angle 10°

- > For hand-operated sockets and accessories with square drive as per DIN 3120 - C 10, ISO 1174, ball locking device

Code	No.	"	"	°	mm	mm	kg
6237680	3093 Z-94	3/8"	10	10	200	18	0,223

30 (MM)
Socket 3/8"
hexagon UD profile

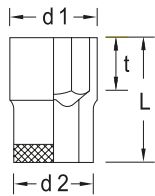

10 3/8"

- > Acc. to DIN 3124, ISO 2725-1
- > Square drive as per DIN 3120 - C 10, ISO 1174, with ball retention groove
- > Hand-operated

* not standardised

Code	No.	mm	L	d1	d2	t	kg
6230160*	30 6	6	28	9,7	17,5	5,0	0,024
6230240	30 7	7	28	11,0	17,5	5,0	0,024
6230320	30 8	8	28	12,1	17,5	9,0	0,028
6230400	30 9	9	28	13,5	17,5	9,0	0,027
6230590	30 10	10	28	14,7	17,5	9,0	0,028
6233850	30 11	11	28	16,0	17,5	9,0	0,03
6233930	30 12	12	28	17,2	18,3	9,0	0,033
6234070	30 13	13	28	18,5	17,5	9,0	0,032
6234150	30 14	14	29	19,7	18,4	11,0	0,038
6234230	30 15	15	30	21,0	19,7	12,5	0,044
6234310	30 16	16	30	22,2	21,0	12,5	0,049
6234580	30 17	17	30	23,5	22,3	12,5	0,057
6234660	30 18	18	23	24,7	23,0	12,5	0,062
6234740	30 19	19	30	26,0	23,7	12,5	0,068
6234820	30 20	20	31	27,2	24,5	12,5	0,078
6234900	30 21	21	31	28,5	25,8	13,5	0,086
6235040	30 22	22	32	29,7	26,3	14,5	0,092
2194783*	30 24	24	33	32,0	28,0	15,5	0,1

30 (AF)
Socket 3/8"
hexagon UD profile

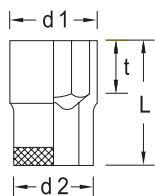

10 3/8"

- > Square drive as per DIN 3120 - C 10, ISO 1174, with ball retention groove
- > Hand-operated

Code	No.	"AF	L	d1	d2	t	kg
6232100	30 1/4AF	1/4"	28	10,1	17,5	5,0	0,023
6232370	30 5/16AF	5/16"	28	12,1	17,5	9,0	0,025
6232450	30 11/32AF	11/32"	28	13,1	17,5	9,0	0,025
6232530	30 3/8AF	3/8"	28	14,1	17,5	9,0	0,026
2101025	30 7/16AF	7/16"	28	16,1	17,5	9,0	0,028
2101033	30 1/2AF	1/2"	28	18,1	19,2	9,0	0,028
2101041	30 9/16AF	9/16"	29	20,1	18,7	11,0	0,039
2101068	30 19/32AF	19/32"	30	21,0	19,7	12,5	0,044
2101076	30 5/8AF	5/8"	30	22,1	20,7	12,5	0,048
2101084	30 11/16AF	11/16"	30	24,0	22,7	12,5	0,06
2101092	30 3/4AF	3/4"	30	26,0	23,7	12,5	0,065
2101106	30 7/8AF	7/8"	32	30,0	26,5	14,5	0,12

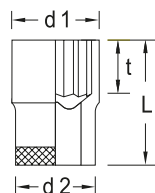
D 30 (MM)Socket 3/8"
Bi-hexagon UD profile**10** $\frac{3}{8}$ "

- > Acc. to DIN 3124, ISO 2725-1
- > Square drive as per DIN 3120 - C 10, ISO 1174, with ball retention groove
- > Hand-operated

*** not standardised**

Code	No.		L	d1	d2	t	
1845705*	D 30 6	6	28	17,5	9,7	5,0	0,02
1845713	D 30 7	7	28	17,5	11,0	5,0	0,024
1845721	D 30 8	8	28	17,5	12,1	9,0	0,026
1845748	D 30 9	9	28	17,5	13,5		0,027
6229230	D 30 10	10	28	17,5	14,7	9,0	0,028
6230670	D 30 11	11	28	17,5	16,0	9,0	0,03
6230750	D 30 12	12	28	18,3	17,2	9,0	0,032
6230830	D 30 13	13	28	17,5	18,5	9,0	0,031
6230910	D 30 14	14	29	18,4	19,7	11,0	0,037
6231050	D 30 15	15	30	19,7	21,0	12,5	0,04
6231130	D 30 16	16	30	21,0	22,2	12,5	0,049
6231210	D 30 17	17	30	22,3	23,5	12,5	0,054
6231480	D 30 18	18	30	23,0	24,7	12,5	0,062
6231560	D 30 19	19	30	23,7	26,0	12,5	0,064
6231640	D 30 20	20	31	24,5	27,2	12,5	0,074
6231720	D 30 21	21	31	25,8	28,5	13,5	0,083
6231800	D 30 22	22	32	26,3	29,7	14,5	0,087
2194864*	D 30 24	24	33	28,0	32,0	15,5	0,1

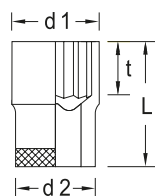
D 30 (AF)Socket 3/8"
Bi-hexagon UD profile**10** $\frac{3}{8}$ "

- > Square drive as per DIN 3120 - C 10, ISO 1174, with ball retention groove
- > Hand-operated

Code	No.		L	d1	d2	t	
2016613	D 30 1/4AF	1/4"	28	17,5	10,1	5,0	0,05
2101009	D 30 9/32AF	9/32"	28	17,5	11,1	5,0	0,02
1997122	D 30 5/16AF	5/16"	28	17,5	12,1	5,0	0,02
2101017	D 30 11/32AF	11/32"	28	17,5	13,1	9,0	0,026
1997130	D 30 3/8AF	3/8"	28	17,5	14,1	9,0	0,01
1997149	D 30 13/32AF	13/32"	28	17,5	15,0	9,0	0,03
6232610	D 30 7/16AF	7/16"	28	17,5	16,1	9,0	0,027
6232880	D 30 1/2AF	1/2"	28	19,2	18,1	9,0	0,034
6232960	D 30 9/16AF	9/16"	29	18,7	20,1	11,0	0,036
6233180	D 30 19/32AF	19/32"	30	19,7	21,0	12,5	0,039
6233260	D 30 5/8AF	5/8"	30	20,7	22,1	12,5	0,044
6233340	D 30 11/16AF	11/16"	30	22,7	24,0	12,5	0,053
6233420	D 30 3/4AF	3/4"	30	23,7	26,0	12,5	0,061
1997157	D 30 25/32AF	25/32"	31	24,3	27,0	12,5	0,075
1997165	D 30 13/16AF	13/16"	31	25,3	28,0	12,5	0,08
6232020	D 30 7/8AF	7/8"	32	26,5	30,0	14,5	0,082
1997173	D 30 15/16AF	15/16"	33	28,0	31,9	15,5	0,11
1983296	D 30 1AF	1"	33	30,0	33,9	15,5	0,12

WWW.GEDORE.COM

D 30 L (MM)

Socket 3/8"
Bi-hexagon UD profile,
long pattern

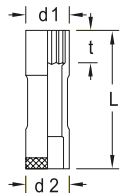

10 $\frac{3}{8}$ "

- > Acc. to DIN 3124, ISO 2725-1
- > Square drive as per DIN 3120 - C 10, ISO 1174, with ball retention groove
- > Hand-operated

Code	No.		L	d1	d2	t	
6258330	D 30 L 10	10	63,5	17,5	14,7	11,0	0,053
6258410	D 30 L 11	11	63,5	17,5	16,0	12,0	0,054
6258680	D 30 L 12	12	63,5	17,5	17,2	14,0	0,059
6258760	D 30 L 13	13	63,5	19,0	18,5	14,0	0,07
6258840	D 30 L 14	14	63,5	19,5	19,7	17,0	0,076
6258920	D 30 L 15	15	63,5	20,5	21,0	17,0	0,095
6259060	D 30 L 16	16	63,5	22,0	22,2	17,0	0,085
6259140	D 30 L 17	17	63,5	20,5	23,5	17,0	0,096
6259220	D 30 L 18	18	63,5	21,5	24,7	20,0	0,113
6259300	D 30 L 19	19	63,5	22,0	26,0	20,0	0,124
6259490	D 30 L 20	20	63,5	23,5	27,2	20,0	0,127
6259570	D 30 L 21	21	63,5	23,5	28,5	20,0	0,134
6259650	D 30 L 22	22	63,5	23,5	29,7	23,0	0,136

D 30 L (AF)

Socket 3/8"
Bi-hexagon UD profile,
long pattern

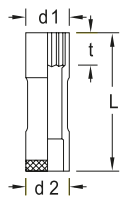

10 $\frac{3}{8}$ "

- > Square drive as per DIN 3120 - C 10, ISO 1174, with ball retention groove
- > Hand-operated

Code	No.		L	d1	d2	t	
6259730	D 30 L 3/8AF	3/8"	63,5	17,5	14,1	11,0	0,051
6259810	D 30 L 7/16AF	7/16"	63,5	17,5	16,1	12,0	0,053
6260070	D 30 L 1/2AF	1/2"	63,5	19,0	18,1	14,0	0,065
6260150	D 30 L 9/16AF	9/16"	63,5	19,5	20,1	17,0	0,073
6260230	D 30 L 5/8AF	5/8"	63,5	22,0	22,1	17,0	0,092
6260310	D 30 L 11/16AF	11/16"	63,5	20,5	24,0	17,0	0,09
6260580	D 30 L 3/4AF	3/4"	63,5	22,0	26,0	20,0	0,109
6260660	D 30 L 13/16AF	13/16"	63,5	23,5	28,3	20,0	0,132
6260740	D 30 L 7/8AF	7/8"	63,5	23,5	30,0	23,0	0,134

DG 30

Swivel socket 3/8"
Bi-hexagon UD profile

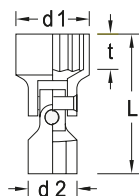

10 $\frac{3}{8}$ "

- > Square drive as per DIN 3120 - C 10, ISO 1174, with ball retention groove
- > Hand-operated

Code	No.		L	d1	d2	t	
6240630	DG 30 10	10	41,5	14,7	19,0	8,0	0,042
6241520	DG 30 13	13	42,5	18,5	19,0	9,0	0,05
6241790	DG 30 15	15	45,5	21,0	19,0	11,0	0,048
6242410	DG 30 18	18	46	24,7	19,0	12,5	0,063
6242680	DG 30 19	19	46,5	26,0	19,0	12,5	0,064

TX 30

Socket 3/8"
for protruding
TX head screws

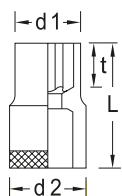

10 $\frac{3}{8}$ "

- > Square drive as per DIN 3120 - C 10, ISO 1174, with ball retention groove
- > Hand-operated

Code	No.				L	d1	d2	t	
6250270	TX 30 E5	E5	M4	4,73	28	7,2	17,5	5,0	0,025
6250350	TX 30 E6	E6	M5	5,74	28	8,5	17,5	5,0	0,025
6250430	TX 30 E7	E7	M6	6,16	28	9,5	17,5	5,5	0,025
6250510	TX 30 E8	E8	M6 - M7	7,52	28	10,8	17,5	6,0	0,027
6250780	TX 30 E10	E10	M8	9,42	28	13,2	17,5	9,0	0,029
6250860	TX 30 E11	E11	-	10,08	28	13,8	17,5	9,0	0,03
6250940	TX 30 E12	E12	M10	11,17	28	15,2	17,5	9,0	0,032
6251080	TX 30 E14	E14	M12	12,9	28	16,8	17,5	9,0	0,035

ITX 30

Screwdriver
bit socket 3/8"
for recessed TX head
screws

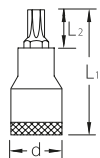

10 **3/8"**

- > Square drive as per DIN 3120 - C 10, ISO 1174, with ball retention groove
- > Hand-operated

Code	No.			mm	L1	L2	d	
6246320	ITX 30 T20	T20	M4 - M5	3,86	49	17,0	17,5	0,05
6246830	ITX 30 T25	T25	M4,5 - M5	4,43	49	17,0	17,5	0,051
6247210	ITX 30 T27	T27	M4,5 - M6	4,99	49	17,0	17,5	0,051
6247560	ITX 30 T30	T30	M6 - M7	5,52	49	17,0	17,5	0,051
6247720	ITX 30 T40	T40	M7 - M8	6,65	49	17,0	17,5	0,052
6247800	ITX 30 T45	T45	M8 - M10	7,82	49	17,0	17,5	0,053
6247990	ITX 30 T50	T50	M10	8,83	49	17,0	19	0,07

ITX 30 L

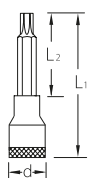
Screwdriver
bit socket 3/8"
for recessed TX head
screws, long pattern



10 **3/8"**

- > Square drive as per DIN 3120 - C 10, ISO 1174, with ball retention groove
- > Hand-operated

Code	No.			mm	L1	L2	d	
1394177	ITX 30 L T20	T20	M4 - M5	3,86	94	62,0	17,5	0,07
1394185	ITX 30 L T25	T25	M4,5 - M5	4,43	94	62,0	17,5	0,07
1394193	ITX 30 L T27	T27	M4,5 - M6	4,99	94	62,0	17,5	0,07
1394207	ITX 30 L T30	T30	M6 - M7	5,52	94	62,0	17,5	0,071
1394215	ITX 30 L T40	T40	M6 - M7	5,52	94	62,0	17,5	0,07
1394223	ITX 30 L T45	T45	M8 - M10	7,82	94	62,0	17,5	0,071
1394231	ITX 30 L T50	T50	M10	8,83	94	62,0	19	0,099

IS 30

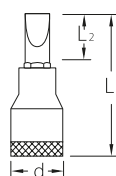
Screwdriver
bit socket 3/8"
for slotted head screws



10 **3/8"**

- > Square drive as per DIN 3120 - C 10, ISO 1174, with ball retention groove
- > Hand-operated
- > Blade tip acc. to DIN ISO 2380-1 Form B

Code	No.		mm	mm	L1	L2	d	
6666100	IS 30 5,5X1		5,5	1,0	55	27,0	17,5	0,04
1640895	IS 30 6,5X1,2		6,5	1,2	55	27,0	17,5	0,039
6666290	IS 30 8X1,2		8,0	1,2	55	23,0	17,5	0,054
6666370	IS 30 10X1,6		10,0	1,6	55	23,0	19	0,072
1640909	IS 30 12X2		12,0	2,0	55	23,0	20,5	0,083

IKS 30

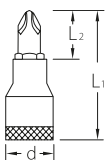
Screwdriver
bit socket 3/8"
for cross-head screws
PH



10 **3/8"**

- > Square drive as per DIN 3120 - C 10, ISO 1174, with ball retention groove
- > Hand-operated
- > Tip as per DIN ISO 8764-1 PH

Code	No.		PH	L1	L2	d	
6666610	IKS 30 1	1		55	27,0	17,5	0,041
6666880	IKS 30 2	2		55	23,0	17,5	0,052
6666960	IKS 30 3	3		55	23,0	19	0,07

IKS 30 PZD

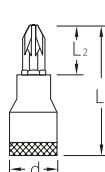
Screwdriver
bit socket 3/8"
for cross-head screws
Pozi PZ



10 **3/8"**

- > Square drive as per DIN 3120 - C 10, ISO 1174, with ball retention groove
- > Hand-operated
- > Tip as per DIN ISO 8764-1 PZ

Code	No.		PZ	L1	L2	d	
1640968	IKS 30 PZD 1	1		55	27,0	17,5	0,04
1640976	IKS 30 PZD 2	2		55	23,0	17,5	0,051
1640984	IKS 30 PZD 3	3		55	23,0	19	0,069

IN 30 (MM)

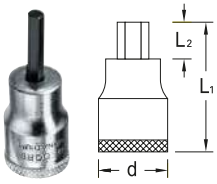
Screwdriver bit socket 3/8" for in-hex screws, long pattern



10 3/8"

- > Acc. to DIN 7422
- > Square drive as per DIN 3120 - C 10, ISO 1174, with ball retention groove
- > Hand-operated

*** not standardised**

Code	No.	mm	L1	L2	d	kg
6241010	IN 30 4	4	47	19,0	17,5	0,038
6241280	IN 30 5	5	47	19,0	17,5	0,039
6241360	IN 30 6	6	47	19,0	17,5	0,041
1643037*	IN 30 7	7	47	19,0	17,5	0,041
6241440	IN 30 8	8	49	17,0	17,5	0,053
6242920	IN 30 10	10	49	17,0	19	0,073

IN 30 (AF)

Screwdriver bit socket 3/8" for in-hex screws

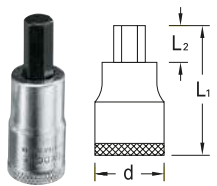

10 3/8"

- > Square drive as per DIN 3120 - C 10, ISO 1174, with ball retention groove
- > Hand-operated

Code	No.	L1	L2	d	kg
2195208	IN 30 1/8AF	47	19,0	17,5	0,035
2195232	IN 30 5/32AF	47	19,0	17,5	0,04
2195267	IN 30 3/16AF	47	19,0	17,5	0,04
1193422	IN 30 1/4AF	47	19,0	17,5	0,049
1193431	IN 30 5/16AF	49	17,0	17,5	0,05
1193449	IN 30 3/8AF	49	17,0	19	0,05

IN 30 L

Screwdriver bit socket 3/8" for in-hex screws, long pattern

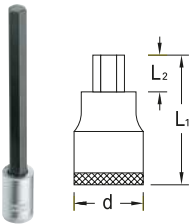

10 3/8"

- > Acc. to DIN 7422
- > Square drive as per DIN 3120 - C 10, ISO 1174, with ball retention groove
- > Hand-operated

Code	No.	mm	L1	L2	d	kg
1510118	IN 30 L 4	4	95	67,0	17,5	0,044
1394347	IN 30 L 5	5	95	67,0	17,5	0,048
1394355	IN 30 L 6	6	95	67,0	17,5	0,053
1394363	IN 30 L 7	7	95	67,0	17,5	0,058
1394371	IN 30 L 8	8	95	63,0	17,5	0,074
1394398	IN 30 L 10	10	95	63,0	17,5	0,105

IN 30 LK

Screwdriver bit socket 3/8"

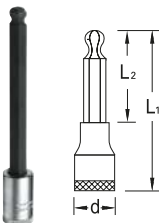

10 3/8"

- > Square drive as per DIN 3120 - C 10, ISO 1174, with ball retention groove
- > Hand-operated
- > Total swivel angle approx. 15-20°

Code	No.	mm	L1	L2	d	kg
1505718	IN 30 LK 4	4	132	104,0	17,5	0,048
1505726	IN 30 LK 5	5	132	104,0	17,5	0,054
1505742	IN 30 LK 6	6	132	104,0	17,5	0,061
1505750	IN 30 LK 8	8	132	102,0	17,5	0,091
1505769	IN 30 LK 10	10	134	102,0	19	0,13

INX 30

Screwdriver bit socket 3/8" for multi-point screws XZN

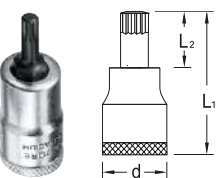

10 3/8"

- > Design according to DIN 2324
- > Square drive as per DIN 3120 - C 10, ISO 1174, with ball retention groove
- > Hand-operated
- > Tip as per DIN 2325

Code	No.	mm	L1	L2	d	kg
6242170	INX 30 5	M5	49	17,0	17,5	0,05
6242250	INX 30 6	M6	49	17,0	17,5	0,051
6242330	INX 30 8	M8	49	17,0	17,5	0,053
2194872	INX 30 10	M10	49	17,0	19	0,078

INX 30 L
Screwdriver
bit socket 3/8"
for multi-point screws
XZN, long pattern

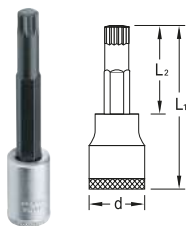

10 **3/8"**

- > Design according to DIN 2324
- > Square drive as per DIN 3120 - C 10, ISO 1174, with ball retention groove
- > Hand-operated
- > Tip as per DIN 2325

Code	No.		L1	L2	d	
1394312	INX 30 L 6	M6	94	62,0	17,5	0,068
1394320	INX 30 L 8	M8	94	62,0	17,5	0,071
1394339	INX 30 L 10	M10	94	62,0	19	0,079

30 JMU / D 30 JMU
Socket set 3/8"
16 pieces



10 **3/8"**

- > With hand-operated 6-sided UD profile (No. 30) or 12-sided UD profile (No. D 30) sockets
- > With operating tools
- > With robust lever-change reversible ratchet
- > In GEDORE blue sheet steel case

Code	No.	Contents	Pieces	
2682885	30 JMU-10	reversible ratchet 3/8" No. 3093 U-10 Socket wrench insert 3/8" hexagon UD profile No. 30 6 7 8 9 10 11 12 13 14 15 16 17 18 19 Extension 3/8" No. 3090-5	16	2,2
2682893	D 30 JMU-10	reversible ratchet 3/8" No. 3093 U-10 Socket wrench insert 3/8" 12-point UD profile No. D 30 6 7 8 9 10 11 12 13 14 15 16 17 18 19 Extension 3/8" No. 3090-5	16	2,3

30 HMU / D 30 HMU
Socket set 3/8"
22 pieces



10 **3/8"**

- > With hand-operated 6-sided UD profile (No. 30) or 12-sided UD profile (No. D 30) sockets
- > With operating tools
- > Set U-3 with fine toothed, dial change ratchet
- > Set U-10 with reversible lever change ratchet
- > In GEDORE blue sheet steel case

Code	No.	Contents	Pieces	
6238300	30 HMU-3	reversible ratchet 3/8" No. 3093 U-3 Socket wrench insert 3/8" hexagon UD profile No. 30 6 7 8 9 10 11 12 13 14 15 16 17 18 19 20 21 22 Cross handle 3/8" No. 3087 Extension 3/8" No. 3090-5 -10 Cardan joint 3/8" No. 3095	22	3
6235470	30 HMU-10	reversible ratchet 3/8" No. 3093 U-10 Socket wrench insert 3/8" hexagon UD profile No. 30 6 7 8 9 10 11 12 13 14 15 16 17 18 19 20 21 22 Cross handle 3/8" No. 3087 Extension 3/8" No. 3090-5 -10 Cardan joint 3/8" No. 3095	22	3
6240470	D 30 HMU-3	reversible ratchet 3/8" No. 3093 U-3 Socket wrench insert 3/8" 12-point UD profile No. D 30 6 7 8 9 10 11 12 13 14 15 16 17 18 19 20 21 22 Cross handle 3/8" No. 3087 Extension 3/8" No. 3090-5 -10 Cardan joint 3/8" No. 3095	22	3,1
6239700	D 30 HMU-10	reversible ratchet 3/8" No. 3093 U-10 Socket wrench insert 3/8" 12-point UD profile No. D 30 6 7 8 9 10 11 12 13 14 15 16 17 18 19 20 21 22 Cross handle 3/8" No. 3087 Extension 3/8" No. 3090-5 -10 Cardan joint 3/8" No. 3095	22	3,1

30 GMU / D 30 GMU

Socket set 3/8"
17 pieces



10 **3/8"**

- > With hand-operated 6-sided UD profile (No. 30) or 12-sided UD profile (No. D 30) sockets
- > With operating tools
- > Set U-3 with fine toothed, dial change ratchet
- > Set U-10 with reversible lever change ratchet
- > In GEDORE blue sheet steel case

Code	No.	Contents	Pieces	
6235980	30 GMU-3	reversible ratchet 3/8" No. 3093 U-3 Socket wrench insert 3/8" hexagon UD profile No. 30 6 7 8 9 10 11 13 14 15 16 17 19 Cross handle 3/8" No. 3087 Extension 3/8" No. 3090-5 -10 Cardan joint 3/8" No. 3095	17	2,6
6235710	30 GMU-10	reversible ratchet 3/8" No. 3093 U-10 Socket wrench insert 3/8" hexagon UD profile No. 30 6 7 8 9 10 11 13 14 15 16 17 19 Cross handle 3/8" No. 3087 Extension 3/8" No. 3090-5 -10 Cardan joint 3/8" No. 3095	17	2,6
6240200	D 30 GMU-3	reversible ratchet 3/8" No. 3093 U-3 Socket wrench insert 3/8" 12-point UD profile No. D 30 6 7 8 9 10 11 13 14 15 16 17 19 Cross handle 3/8" No. 3087 Extension 3/8" No. 3090-5 -10 Cardan joint 3/8" No. 3095	17	2,7
6239380	D 30 GMU-10	reversible ratchet 3/8" No. 3093 U-10 Socket wrench insert 3/8" 12-point UD profile No. D 30 6 7 8 9 10 11 13 14 15 16 17 19 Cross handle 3/8" No. 3087 Extension 3/8" No. 3090-5 -10 Cardan joint 3/8" No. 3095	17	2,7

30 IMU-10

Socket set 3/8"
26 pieces



10 **3/8"**

- > With hand-operated hexagonal UD profile sockets
- > With operating tools
- > Set U-3 with fine toothed, dial change ratchet
- > Set U-10 with reversible lever change ratchet
- > In GEDORE blue sheet steel case

Code	No.	Contents	Pieces	
6229740	30 IMU-10	reversible ratchet 3/8" No. 3093 U-10 Socket wrench insert 3/8" hexagon UD profile No. D 30 6 7 8 9 10 11 12 13 14 15 16 17 19 Screwdriver bit socket 3/8" for slotted screws No. IS 30 5.5x1 8x1.2 Screwdriver bit socket 3/8" for hexagon socket screws No. IN 30 4 5 6 Screwdriver bit socket 3/8" for cross-head screws PH No. IKS 30 PH 2 3 Cross handle 3/8" No. 3087 Extension 3/8" No. 3090-5 -10 Cardan joint 3/8" No. 3095	26	3,1

D 30 KMU-20

Socket set 3/8"
40 pieces

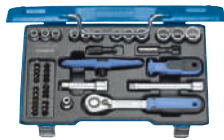

10 **3/8"**

- > With hand operated 12-point UD profile sockets
- > With operating tools
- > With robust lever-operated reversible ratchet and cross-handle ratchet
- > In GEDORE blue sheet steel case

Code	No.	Contents	Pieces	
1973347	D 30 KMU-20	reversible ratchet 3/8" No. 3093 U-20 reversible ratchet 3/8" No. 3093 U-3 T Socket wrench insert 3/8" 12-point UD profile No. 30 8 9 10 11 12 13 14 15 16 17 18 19 Screwdriver bit 1/4" for slotted screws No. 680 4 5 5 6 5 Screwdriver bit 1/4" for hexagon socket screws No. 685 3 4 5 6 Screwdriver bit 1/4" for multi-tooth socket screws XZN No. 685 X 5 6 8 Screwdriver bit 1/4" for recessed TX screws No. 687 TX T10 T15 T20 T25 T27 T30 Screwdriver bit 1/4" for cross-head screws PH No. 690 1 2 Screwdriver bit 1/4" for cross-head screws PZ No. 690 PZD 1 2 Cardan extension 3/8" No. 3090 KR-3 Extension 3/8" No. 3090-5 Bit adapter No. 630 Insert holder No. 673 10 Multi-handle No. 676 Bit holder for machine screwdriver No. 699	40	2,6

D 30 TX20 U-20
Socket set 3/8" + 1/4"
50 pieces

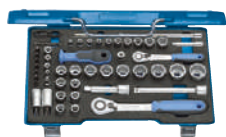

10 **3/8"** **6.3** **1/4"**

- > Tool set for general industrial and automotive applications
- > Inserts 3/8" and 1/4" for inside and outside TX screws
- > With robust lever-change reversible ratchets, with push-button release
- > In GEDORE blue sheet steel case with Check-Tool insert

Code	No.	Contents	Pieces	
2075695	D 30 TX20 U-20	reversible ratchet 3/8" No. 3093 U-20 Reversible ratchet 1/4" No. 2093 U-20 Socket wrench insert 3/8" 12-point UD profile No. D 30 10 11 12 13 14 15 16 17 18 19 21 22 Socket wrench socket 3/8" for outdoor TX screws No. TX 30 E11 E12 E14 Screwdriver bit socket 3/8" for recessed TX screws No. ITX 30 T45 T50 Socket wrench insert 1/4" 12-point UD profile No. D 20 4 5 5.6 7 8 9 10 12 13 Socket wrench insert 1/4" for external TX screws No. TX 20 E5 E6 E7 E8 E10 Screwdriver bit 1/4" for inside TX screws No. 687 TX T10 T15 T20 T25 T27 T30 T40 Cardan extension 3/8" No. 3090 KR-3 Extension 3/8" No. 3090-5 Cardan extension 1/4" No. 2090 KR-5 Extension 1/4" No. 2090-6 Bit adapter No. 620 Insert holder No. 673 6.3 10 Multi-handle No. 676 Bit holder for machine screwdriver No. 699	50	3,2

IN 30 LKM
Screwdriver set 3/8"
10 pieces



10 **3/8"**

- > for in-hex screws, short and long pattern
- > In plastic case

Code	No.	Contents	Pieces	
1509918	IN 30 LKM	Screwdriver bit socket 3/8" for hexagon socket screws No. IN 30 4 5 6 8 10 Screwdriver bit socket 3/8" for in-hex screws, long No. IN 30 L 4 5 6 8 10	10	0,761

ITX 30 PM
Screwdriver set 3/8"
7 pieces



10 **3/8"**

- > for recessed TX head screws
- > In plastic case

Code	No.	Contents	Pieces	
1509926	ITX 30 PM	Screwdriver bit socket 3/8" for recessed TX screws No. ITX 30 T20 T25 T27 T30 T40 T45 T50	7	0,627

ITX 30 TX-015
Screwdriver set 3/8"
15 pieces



10 **3/8"**

- > For protruding and recessed TX screws
- > In plastic case

Code	No.	Contents	Pieces	
1509942	ITX 30 TX-015	Screwdriver bit socket 3/8" for recessed TX screws No. ITX 30 T20 T25 T27 T30 T40 T45 T50 Socket wrench insert 3/8" for external TX screws No. TX 30 E5 E6 E7 E8 E10 E11 E12 E14	15	0,801

3098
Swivel handle 3/8"



- > For hand-operated sockets and accessories with square drive as per DIN 3120, ISO 1174, ball locking device

Code	No.	"	mm	mm	
6182410	3098	3/8"	10	450	0,364

Operating tools and accessories

3096
Swivel handle 3/8"



- > Acc. to DIN 3122, ISO 3315
- > For hand-operated sockets and accessories with square drive as per DIN 3120, ISO 1174, ball locking device

Code	No.	"	mm	mm	kg
6238220	3096	3/8"	10	254	0,201

3087
Sliding T bar 3/8"



- > Acc. to DIN 3122, ISO 3315
- > For hand-operated sockets and accessories with square drive as per DIN 3120, ISO 1174, ball locking device

Code	No.	"	mm	mm	kg
6236520	3087	3/8"	10	163	0,164

3081
L-handle 3/8"



- > Acc. to DIN 3122, ISO 3315
- > For hand-operated sockets and accessories with square drive as per DIN 3120, ISO 1174, ball locking device

Code	No.	"	mm	mm	kg
6236360	3081	3/8"	10	180	0,153

3090
Extension 3/8"



- > Acc. to DIN 3123, ISO 3316
- > For hand-operated sockets and accessories with square drive as per DIN 3120, ISO 1174, ball locking device
- * not standardised**

Code	No.	"	mm	mm	kg
1476637*	3090-2	3/8"	10	50	0,063
6236600	3090-3	3/8"	10	76	0,093
6236790	3090-5	3/8"	10	125	0,117
1476645*	3090-7	3/8"	10	180	0,164
6236870	3090-10	3/8"	10	250	0,222
6238570*	3090-12	3/8"	10	305	0,287
1476653*	3090-20	3/8"	10	500	0,524

3090 KR
Universal extension 3/8"



- > With ball end
- > For hand-operated sockets and accessories with square drive as per DIN 3120, ISO 1174, ball locking device
- > The extension is able to pivot up to 15°

Code	No.	"	mm	mm	kg
1874381	3090 KR-3	3/8"	10	76	0,08
1845756	3090 KR-5	3/8"	10	125	0,108
1845764	3090 KR-10	3/8"	10	250	0,197

3095
Universal joint 3/8"



- > Acc. to DIN 3123, ISO 3316
- > For hand-operated sockets and accessories with square drive as per DIN 3120, ISO 1174, ball locking device

Code	No.	"	mm	"	mm	mm	kg
6238140	3095	3/8"	10,0	3/8"	10	50	0,053

3090 M
Extension 3/8"
with holding magnet



- > For hand-operated sockets with through hole and square drive according to DIN 3120, ISO 1174, with ball locking device
- > One-hand operation - the screw or nut can be screwed in immediately with the socket wrench insert
- > A strong permanent magnet keeps hold of even large screws
- > Especially suitable for work in confined spaces

Code	No.	"	mm	mm	kg
2960060	3090 M	3/8"	10	65	0,065

3094
coupler 3/8"



- > Acc. to DIN 3122, ISO 3315
- > For hand-operated sockets and accessories with square drive as per DIN 3120, ISO 1174, ball locking device

Code	No.	"	mm	mm	kg
6237760	3094	3/8"	10	29	0,02

3019
Convertor
3/8" to 1/2"



- > Acc. to DIN 3123, ISO 3316
- > For hand-operated sockets and accessories with square drive as per DIN 3120, ISO 1174, ball locking device

Code	No.	"	mm	"	mm	mm	kg
6236010	3019	3/8"	10,0	1/2"	12,5	35	0,053

3020
Reducer
3/8" to 1/4"



- > Acc. to DIN 3123, ISO 3316
- > For hand-operated sockets and accessories with square drive as per DIN 3120, ISO 1174, ball locking device

Code	No.	"	mm	"	mm	mm	kg
6236280	3020	3/8"	10,0	1/4"	6,3	28	0,026

SL 3014

Tool holding rail, magnetic 3/8" empty



- > 14 Outer square edge suitable for sockets nominal size 10 (3/8")
- > Two female square adaptors to take ratchets, sliding T bars, extensions etc.

- > A strong magnet securely holds the socket rail to ferrous metals
- > Delivery without tools

Code	No.	mm	mm	kg
1761099	SL 3014	480	33	0,479

VH 30

Spring steel socket rail 3/8"



- > For 14 socket wrench inserts nominal size 10 (3/8")
- > Delivery without tools

Code	No.	mm	mm	kg
5164810	VH 30	405		0,067

1993 U-20 G

Reversible ratchet 1/2" with offset handle

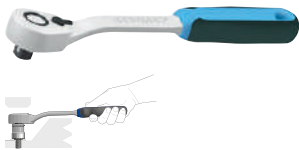

- > Acc. to DIN 3122, ISO 3315
- > Fine-toothed (60 teeth), with lever change and push-button release
- > Return angle 6°

- > For hand-operated sockets and accessories with square drive as per DIN 3120 - C 12.5, ISO 1174, ball locking device

Code	No.	"	mm	°	mm	mm	kg
2746786	1993 U-20 G	1/2"	12,5	6	270	37,5	0,54

1993 U-20

Reversible ratchet 1/2"



- > Acc. to DIN 3122, ISO 3315
- > Fine-toothed (60 teeth), with lever change and push-button release
- > Return angle 6°

- > For hand-operated sockets and accessories with square drive as per DIN 3120 - C 12.5, ISO 1174, ball locking device

Code	No.	"	mm	°	mm	mm	kg
1436686	1993 U-20	1/2"	12,5	6	270	37,5	0,536

1993 U-10 L

Reversible ratchet 1/2" Long pattern



- > Acc. to DIN 3122, ISO 3315
- > with push-button release
- > Return angle 7.5°

- > For hand-operated sockets and accessories with square drive as per DIN 3120 - C 12.5, ISO 1174, ball locking device

Code	No.	"	mm	°	mm	mm	kg
6154550	1993 U-10 L	1/2"	12,5	7,5	350		0,62

1993 U-10 T
Reversible ratchet 1/2"



1/2" **12,5**

- > Acc. to DIN 3122, ISO 3315
- > with push-button release
- > Return angle 7.5°

- > For hand-operated sockets and accessories with square drive as per DIN 3120 - C 12.5, ISO 1174, ball locking device

Code	No.	"	"	°	mm	mm	kg
6142620	1993 U-10 T	1/2"	12,5	7,5	270	39	0,598

1993 ALU-10
Aluminium reversible ratchet 1/2"



1/2" **12,5**

- > Forged and hardened from special aluminium
- > with push-button release
- > Return angle 7.5°

- > For hand-operated sockets and accessories with square drive as per DIN 3120 - C 12.5, ISO 1174, ball locking device

Code	No.	"	"	°	mm	mm	kg
6142700	1993 ALU-10	1/2"	12,5	8	270	39	0,34

1993 U-3
Reversible ratchet 1/2"



1/2" **12,5**

- > Acc. to DIN 3122, ISO 3315
- > With non-slip metal disc change, fine-toothed (72 teeth) and robust
- > Return angle 5°

- > For hand-operated sockets and accessories with square drive as per DIN 3120 - C 12.5, ISO 1174, ball locking device

Code	No.	"	"	°	mm	mm	kg
6144240	1993 U-3	1/2"	12,5	5	270	40,5	0,476

1993 GU-3
Swivel head reversible ratchet 1/2"



1/2" **12,5**

- > 180° swivelling, with joint lock
- > With non-slip metal, fine-toothed (72 teeth) and robust
- > Return angle 5°

- > For hand-operated sockets and accessories with square drive as per DIN 3120 - C 12.5, ISO 1174, ball locking device

Code	No.	"	"	°	mm	mm	kg
6144320	1993 GU-3	1/2"	12,5	5	282	40,5	0,535

1993 TU-10
Telescopic reversible ratchet 1/2"



1/2" **12,5**

- > Long lever arm for high torques, max. torque 600 N·m
- > with push-button release
- > Return angle 7.5°

- > For hand-operated sockets and accessories with square drive as per DIN 3120 - C 12.5, ISO 1174, ball locking device

Code	No.	"	"	°	mm	mm	kg
3041859	1993 TU-10	1/2"	12,5	7,5	400-600		1,31

1993 GU-10 XL

Swivel head reversible ratchet 1/2" extra long



- > Extra long design
- > 180° pivotable
- > with push-button release
- > Return angle 7.5°

- > For hand-operated sockets and accessories with square drive as per DIN 3120 - C 12.5, ISO 1174, ball locking device

Code	No.	1/2"	12,5	7,5°	600	1,16
2018934	1993 GU-10 XL	1/2"	12,5	7,5	600	1,16

1993 Z-94

Ratchet handle 1/2"



- > Acc. to DIN 3122, ISO 3315
- > With square coupler, medium-fine toothed, extremely rugged
- > Return angle 7.5°

- > For hand-operated sockets and accessories with square drive as per DIN 3120 - C 12.5, ISO 1174, ball locking device

Code	No.	1/2"	12,5	7,5°	270	21,9	0,476
6144590	1993 Z-94	1/2"	12,5	7,5	270	21,9	0,476

19

Socket 1/2" hexagon UD profile

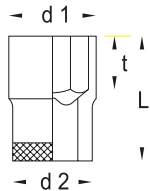

- > Acc. to DIN 3124, ISO 2725-1
- > Square drive as per DIN 3120 - C 12.5, ISO 1174, with ball retention groove
- > Hand-operated

* not standardised

Code	No.	mm	L	d1	d2	t	kg
6130020	19 8	8	38	13,0	22,5	15,0	0,055
6130100*	19 9	9	38	14,2	22,5	15,0	0,056
6130290	19 10	10	38	15,5	22,5	13,5	0,056
6130370	19 11	11	38	16,7	22,5	12,5	0,058
6130450	19 12	12	38	18,0	22,5	12,5	0,058
6130530	19 13	13	38	19,2	22,5	12,5	0,061
6130610	19 14	14	38	20,5	22,5	12,5	0,063
6130880	19 15	15	39,5	21,7	23,8	15,0	0,074
6130960	19 16	16	39,5	22,5	23,8	15,0	0,075
6131180	19 17	17	39,5	24,0	22,5	15,0	0,074
6131260	19 18	18	23	25,5	23,0	17,0	0,073
6131340	19 19	19	40	26,7	24,2	17,0	0,085
6131420	19 20	20	40	28,0	25,5	17,0	0,096
6131500	19 21	21	41,5	29,2	26,0	18,5	0,106
6131690	19 22	22	41,5	30,5	26,3	18,5	0,112
6131770*	19 23	23	41,5	31,7	27,5	18,5	0,122
6131850	19 24	24	41,5	33,0	28,0	18,5	0,132
6131930*	19 25	25	41,5	34,2	28,8	18,5	0,139
6132070*	19 26	26	41,5	35,5	29,4	18,5	0,148
6132150	19 27	27	41,5	36,7	30,0	18,5	0,157
6132230*	19 28	28	43	38,0	30,5	20,0	0,168
6132310*	19 29	29	43	39,2	31,2	20,0	0,181
6132580	19 30	30	43	40,5	32,5	20,5	0,193
6132740	19 32	32	44,5	43,0	34,5	22,5	0,226
2545306*	19 33	33	44,5	44,2	36,0	22,5	0,226
6138270*	19 34	34	44,5	45,5	37,0	22,5	0,259
1718711*	19 36	36	44,5	48,0	38,0	22,5	0,271

19 L
Socket 1/2"
hexagon UD-profile,
long pattern

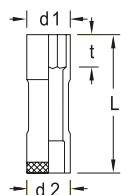

12,5 1/2"

- > Acc. to DIN 3124, ISO 2725-1
- > Square drive as per DIN 3120 - C 12.5, ISO 1174, with ball retention groove
- > Hand-operated

Code	No.	mm	L	d1	d2	t	kg
1718738	19 L 10	10	77	15,5	22,5	12,0	0,117
1718746	19 L 11	11	77	16,7	22,5	13,0	0,121
1718754	19 L 12	12	77	18,0	22,5	14,0	0,127
1718762	19 L 13	13	77	19,2	22,5	16,0	0,098
1718770	19 L 14	14	77	20,5	22,5	16,5	0,109
1718789	19 L 15	15	77	21,7	22,5	16,5	0,117
1718800	19 L 16	16	77	23,0	24,0	16,5	0,13
1718819	19 L 17	17	77	24,0	24,0	16,5	0,132
1718827	19 L 18	18	82	25,5	25,0	20,0	0,147
1718835	19 L 19	19	82	26,7	26,0	22,0	0,174
2300559	19 L 21	21	82	29,2	28,5	24,0	0,211
2300567	19 L 22	22	82	30,5	28,5	24,0	0,219
2300575	19 L 24	24	82	33,0	29,0	26,0	0,257
2300583	19 L 27	27	82	36,7	30,0	30,0	0,29
2300591	19 L 30	30	82	40,5	32,5	33,0	0,351
2300605	19 L 32	32	82	43,0	34,5	36,0	0,387
2300613	19 L 34	34	82	45,5	36,5	37,0	0,432

D 19 (MM)
Socket 1/2"
Bi-hexagon UD profile

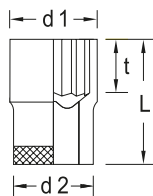

12,5 1/2"

- > Acc. to DIN 3124, ISO 2725-1
- > Square drive as per DIN 3120 - C 12.5, ISO 1174, with ball retention groove
- > Hand-operated
- * not standardised**

Code	No.	mm	L	d1	d2	t	kg
6133040	D 19 8	8	38	22,5	13,0	7,0	0,051
6133120*	D 19 9	9	38	22,5	14,2	8,0	0,052
6133200	D 19 10	10	38	22,5	15,5	13,5	0,056
6133390	D 19 11	11	38	22,5	16,7	12,5	0,057
6133470	D 19 12	12	38	22,5	18,0	12,5	0,057
6133550	D 19 13	13	38	22,5	19,2	12,5	0,059
6133630	D 19 14	14	38	22,5	20,5	12,5	0,061
6133710	D 19 15	15	39,5	23,8	21,7	15,0	0,072
6133980	D 19 16	16	39,5	23,8	22,5	15,0	0,072
6134010	D 19 17	17	39,5	22,5	24,0	15,0	0,07
6134280	D 19 18	18	39,5	23,0	25,5	17,0	0,068
6134360	D 19 19	19	40	24,2	26,7	17,0	0,081
6134440	D 19 20	20	40	25,5	28,0	17,0	0,09
6134520	D 19 21	21	41,5	26,0	29,2	18,5	0,101
6134600	D 19 22	22	41,5	26,3	30,5	18,5	0,106
6134790*	D 19 23	23	41,5	27,5	31,7	18,5	0,118
6134870	D 19 24	24	41,5	28,0	33,0	18,5	0,123
6134950*	D 19 25	25	41,5	28,8	34,2	18,5	0,131
6135090*	D 19 26	26	41,5	29,4	35,5	18,5	0,139
6135170	D 19 27	27	41,5	30,0	36,7	18,5	0,143
6135250*	D 19 28	28	43	30,5	38,0	20,0	0,163
6135330*	D 19 29	29	43	31,2	39,2	20,0	0,168
6135410	D 19 30	30	43	32,5	40,5	20,5	0,182
6135760	D 19 32	32	44,5	34,5	43,0	22,5	0,204
6135840*	D 19 33	33	44,5	36,0	44,2	22,5	0,221
2545314*	D 19 34	34	44,5	37,0	45,5	22,5	0,23
2194686*	D 19 36	36	44,5	38,0	48,0	22,5	0,271

D 19 (AF)

Socket 1/2"
Bi-hexagon UD profile

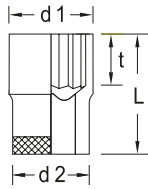

12,5 1/2"

- > Square drive as per DIN 3120 - C 12.5, ISO 1174, with ball retention groove
- > Hand-operated

Code	No.		L	d1	d2	t	
6136060	D 19 5/16AF	5/16"	38	22,5	13,0	7,0	0,052
6136140	D 19 11/32AF	11/32"	38	22,5	13,9	8,0	0,054
6136220	D 19 3/8AF	3/8"	38	22,5	14,9	15,0	0,055
6136300	D 19 13/32AF	13/32"	38	22,5	15,9	13,5	0,055
6136490	D 19 7/16AF	7/16"	38	22,5	16,7	12,5	0,056
6136570	D 19 1/2AF	1/2"	38	22,5	18,7	12,5	0,058
6136650	D 19 9/16AF	9/16"	38	22,5	20,7	12,5	0,061
6136730	D 19 19/32AF	19/32"	39,5	23,8	21,7	15,0	0,07
6136810	D 19 5/8AF	5/8"	39,5	23,8	22,5	15,0	0,073
6137030	D 19 11/16AF	11/16"	39,5	22,5	24,7	17,0	0,066
6137110	D 19 3/4AF	3/4"	40	24,2	26,7	17,0	0,084
6137380	D 19 25/32AF	25/32"	40	25,3	27,7	17,0	0,09
6137460	D 19 13/16AF	13/16"	41,5	25,7	28,5	41,5	0,097
6137540	D 19 7/8AF	7/8"	41,5	26,5	30,6	18,5	0,105
6137620	D 19 15/16AF	15/16"	41,5	28,3	32,6	18,5	0,126
6137700	D 19 1AF	1"	41,5	28,9	34,6	18,5	0,138
6137890	D 19 1.1/16AF	1.1/16"	41,5	30,0	36,7	41,5	0,147
6137970	D 19 1.1/8AF	1.1/8"	43	31,0	38,6	20,0	0,159
6138000	D 19 1.3/16AF	1.3/16"	43	32,5	40,6	20,5	0,183
6138190	D 19 1.1/4AF	1.1/4"	44,5	34,5	42,6	22,5	0,207

D 19 (WW)

Socket 1/2"
bi-hexagon

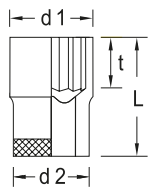

12,5 1/2"

- > Square drive as per DIN 3120 - C 12.5, ISO 1174, with ball retention groove
- > Hand-operated

Code	No.		L	d1	d2	t	
6138780	D 19 3/16W	3/16W	38	22,5	17,0	12,5	0,054
6138860	D 19 1/4W	1/4W	38	22,5	19,5	12,5	0,057
6138940	D 19 5/16W	5/16W	39,5	23,8	21,9	15,0	0,069
6139080	D 19 3/8W	3/8W	39,5	23,0	25,5	17,0	0,066
6139160	D 19 7/16W	7/16W	41,5	26,0	28,8	18,5	0,096
6139240	D 19 1/2W	1/2W	41,5	32,1	27,8	18,5	0,124
6139320	D 19 9/16W	9/16W	41,5	29,2	34,9	18,5	0,137
6139400	D 19 5/8W	5/8W	43	30,5	37,8	20,0	0,166
6139590	D 19 11/16W	11/16W	43	33,0	41,0	20,5	0,184
6138430	D 19 3/4W	3/4W	44,5	36,0	44,2	22,5	0,225

D 19 L (MM)

Socket 1/2"
Bi-hexagon UD profile,
long pattern

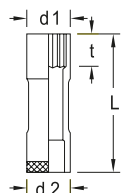

12,5 1/2"

- > Acc. to DIN 3124, ISO 2725-1
- > Square drive as per DIN 3120 - C 12.5, ISO 1174, with ball retention groove
- > Hand-operated
- > Sizes 16, 18, 21 mm with hole drilled for tommy bar Ø 8 mm

Code	No.		L	d1	d2	t	
6141140	D 19 L 10	10	77	22,5	15,5	12,0	0,117
6141220	D 19 L 12	12	77	22,5	18,0	14,0	0,127
6140170	D 19 L 13	13	77	22,5	19,2	16,0	0,101
6140250	D 19 L 14	14	77	22,5	20,5	16,5	0,109
6142460	D 19 L 15	15	77	22,5	21,7	16,5	0,119
6142540	D 19 L 16	16	77	24,0	23,0	16,5	0,128
6140330	D 19 L 17	17	77	24,0	24,0	16,5	0,133
6142380	D 19 L 18	18	82	25,0	25,5	20,0	0,147
6140410	D 19 L 19	19	82	26,0	26,7	22,0	0,175
6140680	D 19 L 21	21	82	28,5	29,2	24,0	0,211
6145050	D 19 L 22	22	82	28,5	30,5	24,0	0,219
6140760	D 19 L 24	24	82	29,0	33,0	26,0	0,257
6141060	D 19 L 27	27	82	30,0	36,7	30,0	0,29
6145640	D 19 L 30	30	82	32,5	40,5	33,0	0,351
6191320	D 19 L 32	32	82	34,5	43,0	36,0	0,387
6147500	D 19 L 34	34	82	36,5	45,5	37,0	0,432

D 19 L (AF)

Socket 1/2"
Bi-hexagon UD profile,
long pattern

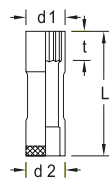

12,5 1/2"

- > Square drive as per DIN 3120 - C 12.5, ISO 1174, with ball retention groove
- > Hand-operated

Code	No.	⊕	L	d1	d2	t	⚖
6141300	D 19 L 1/2AF	1/2"	77	22,5	18,7	16,0	0,095
6141490	D 19 L 9/16AF	9/16"	77	22,5	20,7	16,5	0,105
6141570	D 19 L 5/8AF	5/8"	77	24,0	22,5	16,5	0,12
6141650	D 19 L 11/16AF	11/16"	77	24,8	24,7	16,5	0,143
6141730	D 19 L 3/4AF	3/4"	82	26,0	26,7	22,0	0,164
6141810	D 19 L 13/16AF	13/16"	82	28,5	28,5	22,0	0,197
6142030	D 19 L 7/8AF	7/8"	82	28,5	30,6	24,0	0,208
6142110	D 19 L 15/16AF	15/16"	82	29,0	32,6	26,0	0,234

TX 19

Socket 1/2"
for protruding
TX head screws

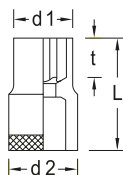

12,5 1/2"

- > Square drive as per DIN 3120 - C 12.5, ISO 1174, with ball retention groove
- > Hand-operated

Code	No.	★ mm	⊕ M	★ mm	L	d1	d2	t	⚖
6145720	TX 19 E10	E10	M8	9,42	38	13,5	22,5	15,5	0,056
6194180	TX 19 E11	E11	-	10,08	38	14,0	22,5	15,5	0,055
6147340	TX 19 E12	E12	M10	11,17	38	15,5	22,5	15,5	0,059
6147420	TX 19 E14	E14	M12	12,9	38	17,0	22,5	13,0	0,059
6194420	TX 19 E16	E16	M12	14,76	38	19,0	22,5	13,0	0,062
6194500	TX 19 E18	E18	M14	16,7	40	21,0	24,5	14,0	0,078
6194690	TX 19 E20	E20	M16	18,45	40	23,5	24,5	14,0	0,085
6195070	TX 19 E24	E24	M18 - M20	22,16	41,5	28,5	26,0	16,0	0,116

ITX 19

Screwdriver
bit socket 1/2"
for recessed
TX screws, short

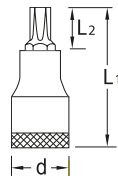

12,5 1/2"

- > Square drive as per DIN 3120 - C 12.5, ISO 1174, with ball retention groove
- > Hand-operated

Code	No.	⊕	⊕ M	★ mm	L1	L2	d	⚖
6152930	ITX 19 T20	T20	M4 - M5	3,86	55	17,0	22,5	0,076
6154200	ITX 19 T25	T25	M4,5 - M5	4,43	55	17,0	22,5	0,075
6154630	ITX 19 T27	T27	M4,5 - M6	4,99	55	17,0	22,5	0,076
6156170	ITX 19 T30	T30	M6 - M7	5,52	55	17,0	22,5	0,075
6156330	ITX 19 T40	T40	M7 - M8	6,65	55	17,0	22,5	0,076
6157060	ITX 19 T45	T45	M8 - M10	7,82	55	17,0	22,5	0,077
6158030	ITX 19 T50	T50	M10	8,83	55	17,0	22,5	0,092
6158380	ITX 19 T55	T55	M12	11,22	55	17,0	23	0,107
6158540	ITX 19 T60	T60	M14	13,25	55	15,0	24,7	0,137

ITX 19 L

Screwdriver
bit socket 1/2"
for recessed
TX head screws

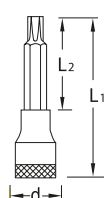
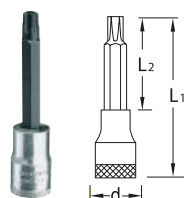

12,5 1/2"

- > Square drive as per DIN 3120 - C 12.5, ISO 1174, with ball retention groove
- > Hand-operated

Code	No.	⊕	⊕ M	★ mm	L1	L2	d	⚖
6188020	ITX 19 LT20-100	T20	M4 - M5	3,86	100	62,0	22,5	0,095
6188100	ITX 19 LT25-100	T25	M4,5 - M5	4,43	100	62,0	22,5	0,095
6188370	ITX 19 LT27-100	T27	M4,5 - M5	4,99	100	62,0	22,5	0,096
6152500	ITX 19 LT30-100	T30	M6 - M7	5,52	100	62,0	22,5	0,096
6152690	ITX 19 LT40-100	T40	M7 - M8	6,65	100	62,0	22,5	0,096
6155870	ITX 19 LT45-100	T45	M8 - M10	7,82	100	62,0	22,5	0,098
6158700	ITX 19 LT50-100	T50	M10	8,83	100	62,0	22,5	0,124
6159940	ITX 19 LT55-100	T55	M12	11,22	100	62,0	23	0,151
6188450	ITX 19 LT60-100	T60	M14	13,25	100	60,0	24,7	0,197
6105180	ITX 19 LT70-100	T70	M16	15,55	100	60,0	28	0,277

ITX 19 B

Screwdriver bit socket 1/2" for recessed TX head screws with pilot

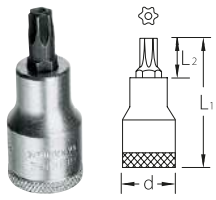

12,5 1/2"

- > Square drive as per DIN 3120 - C 12.5, ISO 1174, with ball retention groove
- > Hand-operated

Code	No.	⊕	mm	mm	L1	L2	d	Bore mm	kg
6192720	ITX 19 B T20	T20	M4 - M5	3,86	55	17,0	22,5	1,55 x 1,86	0,075
6195660	ITX 19 B T25	T25	M4,5 - M5	4,43	55	17,0	22,5	1,93 - 2,04	0,075
6196390	ITX 19 B T27	T27	M4,5 - M6	4,99	55	17,0	22,5	2,18 - 2,29	0,076
6200170	ITX 19 B T30	T30	M6 - M7	5,52	55	17,0	22,5	2,56 - 2,92	0,076
6200410	ITX 19 B T40	T40	M7 - M8	6,65	55	17,0	22,5	2,92 - 3,28	0,091
6200840	ITX 19 B T45	T45	M8 - M10	7,82	55	17,0	22,5	3,45 - 3,68	0,092
6201300	ITX 19 B T50	T50	M10	8,83	55	17,0	23	3,78 - 3,83	0,105
6202700	ITX 19 B T55	T55	M12	11,22	55	15,0	24,7	4,79 - 4,85	0,133
6203270	ITX 19 B T60	T60	M14	13,25	55	16,0	28	5,63 - 7,87	0,182

IS 19

Screwdriver bit socket 1/2" for slotted head screws



12,5 1/2"

- > Square drive as per DIN 3120 - C 12.5, ISO 1174, with ball retention groove
- > Hand-operated
- > Blade tip acc. to DIN ISO 2380-1 Form B

Code	No.	mm	mm	L1	L2	d	kg
6161760	IS 19 6,5X1,2	6,5	1,2	60	22,0	22,5	0,071
6656060	IS 19 8X1,2	8,0	1,2	60	22,0	22,5	0,08
6656140	IS 19 10X1,6	10	1,6	60	22,0	22,5	0,115
6656220	IS 19 12X2	12,0	2,0	60	22,0	23	0,11
6162140	IS 19 14X2,5	14,0	2,5	60	20,0	24,7	0,138
6656490	IS 19 16X2,5	16,0	2,5	60	20,0	28	0,19
6656570	IS 19 18X2,5	18,0	2,5	60	20,0	27	0,193

IKS 19

Screwdriver bit socket 1/2" for cross-head screws PH



12,5 1/2"

- > Square drive as per DIN 3120 - C 12.5, ISO 1174, with ball retention groove
- > Hand-operated
- > Tip as per DIN ISO 8764-1 PH

Code	No.	⊕ PH	L1	L2	d	kg
6656650	IKS 19 2	2	60	22,0	22,5	0,077
6656730	IKS 19 3	3	60	22,0	22,5	0,092
6656810	IKS 19 4	4	60	22,0	23	0,106

IKS 19 PZD

Screwdriver bit socket 1/2" for cross-head screws Pozi PZ

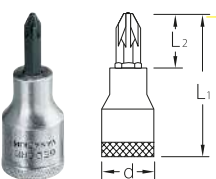

12,5 1/2"

- > Square drive as per DIN 3120 - C 12.5, ISO 1174, with ball retention groove
- > Hand-operated
- > Tip as per DIN ISO 8764-1 PZ

Code	No.	⊕ PZ	L1	L2	d	kg
6156680	IKS 19 PZD 2	2	60	22,0	22,5	0,077
6156760	IKS 19 PZD 3	3	60	22,0	22,5	0,091
6156840	IKS 19 PZD 4	4	60	22,0	23	0,108

IN 19 (MM)
Screwdriver
bit socket 1/2"
for in-hex screws

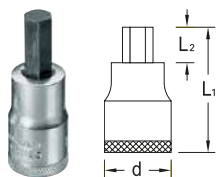

12,5 1/2"

- > Acc. to DIN 7422
- > Square drive as per DIN 3120 - C 12.5, ISO 1174, with ball retention groove
- > Hand-operated
- > chrome-plated

*** not standardised**

Code	No.	mm	L1	L2	d	kg
6153070*	IN 19 4	4	60	22,0	22,5	0,068
6153150*	IN 19 5	5	60	22,0	22,5	0,069
6153230	IN 19 6	6	60	22,0	22,5	0,07
6153310	IN 19 7	7	60	22,0	22,5	0,075
6153580	IN 19 8	8	60	22,0	22,5	0,082
6153660*	IN 19 9	9	60	22,0	22,5	0,091
6153740	IN 19 10	10	60	22,0	22,5	0,099
6153820	IN 19 12	12	60	22,0	23	0,113
6153900	IN 19 14	14	60	20,0	24,7	0,149
6154040*	IN 19 17	17	60	20,0	28	0,21
6154120*	IN 19 19	19	60	20,0	27	0,222

IN 19 (AF)
Screwdriver
bit socket 1/2"
for in-hex screws

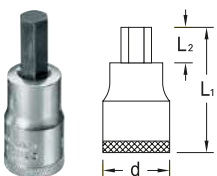

12,5 1/2"

- > Square drive as per DIN 3120 - C 12.5, ISO 1174, with ball retention groove
- > Hand-operated

Code	No.	L1	L2	d	kg
6154710	IN 19 3/16AF	60	22,0	22,5	0,069
6154980	IN 19 7/32AF	60	22,0	22,5	0,069
6155010	IN 19 1/4AF	60	22,0	22,5	0,073
6155280	IN 19 9/32AF	60	22,0	22,5	0,076
6155360	IN 19 5/16AF	60	22,0	22,5	0,081
6155440	IN 19 3/8AF	60	22,0	22,5	0,098
6155520	IN 19 1/2AF	60	22,0	23	0,119
6155600	IN 19 9/16AF	60	20,0	24,7	0,15
6155790	IN 19 5/8AF	60	20,0	28	0,205

IN 19 L
Screwdriver bit socket
1/2"

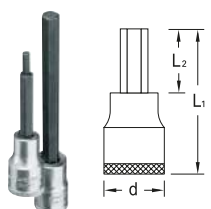

12,5 1/2"

- > Acc. to DIN 7422
- > Square drive as per DIN 3120 - C 12.5, ISO 1174, with ball retention groove
- > Hand-operated

*** not standardised**

Code	No.	mm	L1	L2	d	kg
6162060*	IN 19 L 5-90	5	90	52,0	22,5	0,091
6157140*	IN 19 L 5-180	5	180	142,0	22,5	0,131
6157300	IN 19 L 6-90	6	90	52,0	22,5	0,079
6145800	IN 19 L 6-140	6	140	102,0	22,5	0,115
6145990	IN 19 L 6-160	6	160	122,0	22,5	0,123
6157570	IN 19 L 7-100	7	100	62,0	22,5	0,089
2950960*	IN 19 L 7-140	7	140	102,0	22,5	0,1
6157730	IN 19 L 8-90	8	90	52,0	22,5	0,095
6157810	IN 19 L 8-120	8	120	82,0	22,5	0,109
2951533*	IN 19 L 8-140	8	140	102,0	22,5	0,115
2950979*	IN 19 L 9-140	9	140	102,0	22,5	0,13
6158110	IN 19 L 10-140	10	140	102,0	22,5	0,154
6158460	IN 19 L 12-140	12	140	102,0	22,5	0,195
6158620	IN 19 L 14-140	14	140	100,0	24,7	0,257

IN 19 K

Screwdriver bit socket 1/2" with ball end, for in-hex screws, long pattern

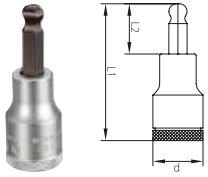

12,5 1/2"

- > Square drive as per DIN 3120 - C 12.5, ISO 1174, with ball retention groove
- > Hand-operated
- > Total swivel angle approx. 15-20°

Code	No.	mm	L1	L2	d	kg
2219336	IN 19 K 6	6	60	22,0	22,5	0,068
2219360	IN 19 K 7	7	60	22,0	22,5	0,071
2219379	IN 19 K 8	8	60	22,0	22,5	0,08
2219395	IN 19 K 10	10	60	22,0	22,5	0,1
1621513	IN 19 K 12	12	60	20,0	23	0,19
2663090	IN 19 K 14	14	60	20,0	24,7	0,22

IN 19 LK

Screwdriver bit socket 1/2" with ball end, for in-hex screws, long pattern

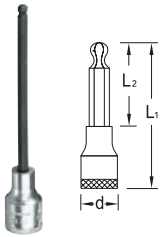

12,5 1/2"

- > Square drive as per DIN 3120 - C 12.5, ISO 1174, with ball retention groove
- > Hand-operated
- > Total swivel angle approx. 15-20°

Code	No.	mm	L1	L2	d	kg
6162810	IN 19 LK 6-140	6	140	102,0	22,5	0,091
6165080	IN 19 LK 7-140	7	140	102,0	22,5	0,103
6165160	IN 19 LK 8-140	8	140	102,0	22,5	0,116
6166800	IN 19 LK 10-140	10	140	102,0	22,5	0,153
6172370	IN 19 LK 12-140	12	140	102,0	23	0,195
1936328	IN 19 LK 14-140	14	140	100,0	24,7	0,225

INR 19 L

Screwdriver bit socket 1/2" for multi-spline screws RIBE®, long pattern



12,5 1/2"

- > RIBE® = reg. trademark of Richard Bergner GmbH & Co. KG, Schwabach

Code	No.		L1	L2	d	kg
1449850	INR 19 L 6-100	M6	100	62,0	22,5	0,085
1450859	INR 19 L 6-188	M6	188	150,0	22,5	0,12
1449877	INR 19 L 8-100	M8	100	62,0	22,5	0,085
1449591	INR 19 L 10-100	M10	100	62,0	22,5	0,105
1450891	INR 19 L 10-188	M10	188	150,0	22,5	0,165

INX 19

Screwdriver bit socket 1/2" for multi-point screws XZN



12,5 1/2"

- > Design according to DIN 2324
- > Square drive as per DIN 3120 - C 12.5, ISO 1174, with ball retention groove
- > Hand-operated
- > Tip as per DIN 2325
- * not standardised**

Code	No.		L1	L2	d	kg
6158890*	INX 19 5	M5	55	17,0	22,5	0,075
6159000*	INX 19 6	M6	55	17,0	22,5	0,076
6159270	INX 19 8	M8	55	17,0	22,5	0,077
6159430	INX 19 10	M10	55	17,0	22,5	0,094
6159780	INX 19 12	M12	55	17,0	23	0,11
1888943	INX 19 14	M14	57	17,0	24,7	0,14
2950944*	INX 19 16	M16	60	20,0	24,7	0,145
2950952*	INX 19 18	M18	60	20,0	24,7	0,15

INX 19 L

Screwdriver bit socket 1/2" for multi-point screws XZN, long pattern

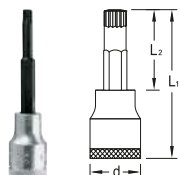

12,5 1/2"

- > Design according to DIN 2324
- > Square drive as per DIN 3120 - C 12.5, ISO 1174, with ball retention groove
- > Hand-operated
- > Tip as per DIN 2325
- * not standardised**

Code	No.		L1	L2	d	kg
6159190*	INX 19 L 6-100	M6	100	62,0	22,5	0,093
6159350	INX 19 L 8-100	M8	100	62,0	22,5	0,097
6159510	INX 19 L 10-100	M10	100	62,0	22,5	0,124
6159860	INX 19 L 12-100	M12	100	62,0	23	0,149
1888951	INX 19 L 14-100	M14	100	60,0	24,7	0,19

19 SKU-20
Socket set 1/2"
14 pieces



- > With hand-operated sockets No. 19 SK with external hexagon drive
- > With robust lever-change reversible ratchet with in-hex drive
- > Fine toothed, return angle 6°
- > In GEDORE blue sheet steel case

Code	No.	Contents	Pieces	
2521563	19 SKU-20	Ratchet 1993 U-20 SK Inserts 19 SK 10 11 12 13 14 15 16 17 18 19 21 22 24	14	1,7

1993 U-20 SK
Reversible ratchet 1/2"



- > Especially suitable for threaded bolts and difficult to access spaces
- > With hexagon drive
- > Fine-toothed (60 teeth), with lever change
- > Return angle 6°
- > For hand-operated sockets with hexagon no. 19 SK

Code	No.				
2219492	1993 U-20 SK	6	270	21	0,51

19 SK
Socket 1/2"
hexagon,
short pattern

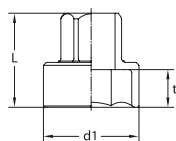

- > With hexagon drive size 18.95 mm
- > For use with reversible ratchet no. 1993 U-20 SK
- > Torques according to DIN 3124 are exceeded

Code	No.		L	d1	t	
2521539	19 SK 10	10	24	15,5	6,0	0,04
2521547	19 SK 11	11	137	16,7	6,0	0,04
2521555	19 SK 12	12	25	18,0	7,0	0,04
2225875	19 SK 13	13	25	19,2	7,0	0,04
2225883	19 SK 14	14	25	20,5	7,0	0,04
2225891	19 SK 15	15	26,5	21,7	8,5	0,04
2225905	19 SK 16	16	26,5	22,5	8,5	0,091
2225913	19 SK 17	16	27	24,0	8,5	0,04
2225921	19 SK 18	18	31	25,5	11,0	0,04
2225948	19 SK 19	19	31	26,7	11,0	0,081
2225964	19 SK 21	21	33	29,2	13,0	0,04
2225972	19 SK 22	22	33	30,5	13,0	0,121
2225980	19 SK 24	24	33	33,0	13,0	0,151

19 SK-8Bit
Bit holder 5/16",
for SK ratchet



- > The bit holder turns the 1993 U-20 SK reversible ratchet into a bit ratchet
- > Hexagon socket according to DIN 3126 - D8 (5/16")

Code	No.		
3064735	19 SK-8BIT	120	0,06

19 SK-19V
Adopter



- > Makes the SK ratchet compatible with 1/2" sockets
- > with push-button release
- > For hand-operated sockets
- > Square drive as per DIN 3120, ISO 1174

Code	No.	1/2"	12,5	kg
3064743	19 SK-19V	1/2"	12,5	0,06

D 19 TMU-10
Socket set 1/2"
25 pieces



12,5 1/2"

- > With hand-operated 6-sided UD profile (No. 19) or 12-sided UD profile (No. D 19) sockets
- > With operating tools
- > With robust lever-change reversible ratchet, with push-button release
- > In GEDORE blue sheet steel case

Code	No.	Contents	Pieces	kg
6151960	D 19 TMU-10	reversible ratchet 1/2" No. 1993 U-10 T Socket wrench insert 1/2" 12-point UD profile No. D 19 10 11 12 13 14 15 16 17 18 19 21 22 23 24 26 27 28 30 32 Crank 1/2" No. 1985 Cross handle 1/2" No. 1987 Extension 1/2" No. 1990-5 -10 Cardan joint 1/2" No. 1995	25	6,6

19 DMU-20
Socket set 1/2"
15 pieces



12,5 1/2"

- > With hand operated hexagonal UD profile sockets
- > With operating tools
- > With robust lever-change reversible ratchet, with push-button release
- > With universal extension, is able to pivot up to 15°

Code	No.	Contents	Pieces	kg
3014347	19 DMU-20	reversible ratchet 1/2" No. 1993 U-20 Socket wrench insert 1/2" hexagon UD profile No. 19 10 12 13 15 16 17 18 19 22 24 27 30 32 Cardan extension 1/2" No. 1990 KR-10	15	5,142

19 KMU / D 19 KMU
Socket set 1/2"
13 pieces



12,5 1/2"

- > With hand-operated 6-sided UD profile (No. 19) or 12-sided UD profile (No. D 19) sockets
- > With operating tools
- > With robust lever-change reversible ratchet, with push-button release
- > In GEDORE blue sheet steel case

Code	No.	Contents	Pieces	kg
2545810	19 KMU-20	reversible ratchet 1/2" No. 1993 U-20 Socket wrench insert 1/2" hexagon UD profile No. 19 10 12 13 14 15 16 17 18 19 22 24 Extension 1/2" No. 1990-5	13	2,6
2545829	D 19 KMU-20	reversible ratchet 1/2" No. 1993 U-20 Socket wrench insert 1/2" 12-point UD profile No. D 19 10 12 13 14 15 16 17 18 19 22 24 Extension 1/2" No. 1990-5	13	2,6

19 JMU
Socket set 1/2"
19 pieces



12,5 1/2"

- > With hand-operated hexagonal UD profile sockets
- > With operating tools
- > With fine toothed, dial change ratchet
- > In GEDORE blue sheet steel case

Code	No.	Contents	Pieces	
2682842	19 JMU-3	reversible ratchet 1/2" No. 1993 U-3 Socket wrench insert 1/2" hexagon UD profile No. 19 8 9 10 11 12 13 14 15 16 17 18 19 21 22 24 Extension 1/2" No. 1990-5 -10 Cardan joint 1/2" No. 1995	19	3,7

19 EMU / D 19 EMU
Socket set 1/2"
23 pieces



12,5 1/2"

- > With hand-operated 6-sided UD profile (No. 19) or 12-sided UD profile (No. D 19) sockets
- > With operating tools
- > Set U-20 with robust lever-change reversible ratchet, with push-button release
- > In GEDORE blue sheet steel case

Code	No.	Contents	Pieces	
2545837	19 EMU-20	reversible ratchet 1/2" No. 1993 U-20 Socket wrench insert 1/2" 12-point UD profile No. D 19 8 9 10 11 12 13 14 15 16 17 18 19 21 22 24 27 30 32 Cross handle 1/2" No. 1987 Extension 1/2" No. 1990-5 -10 Cardan joint 1/2" No. 1995	23	5,7

2545845	D 19 EMU-20	reversible ratchet 1/2" No. 1993 U-20 Socket wrench insert 1/2" 12-point UD profile No. D 19 8 9 10 11 12 13 14 15 16 17 18 19 21 22 24 27 30 32 Cross handle 1/2" No. 1987 Extension 1/2" No. 1990-5 -10 Cardan joint 1/2" No. 1995	23	6,7
----------------	-------------	---	----	-----

19 VMU / D 19 VMU
Socket set 1/2"
28 pieces

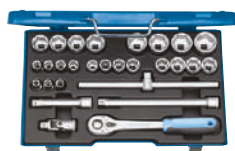

12,5 1/2"

- > With hand-operated 6-sided UD profile (No. 19) or 12-sided UD profile (No. D 19) sockets
- > With operating tools
- > With robust lever-change reversible ratchet, with push-button release
- > In GEDORE blue sheet steel case

Code	No.	Contents	Pieces	
2682869	19 VMU-10	reversible ratchet 1/2" No. 1993 U-10 T Socket wrench insert 1/2" hexagon UD profile No. 19 10 11 12 13 14 15 16 17 18 19 20 21 22 23 24 26 27 28 30 32 33 34 36 Cross handle 1/2" No. 1987 Extension 1/2" No. 1990-5 -10 Cardan joint 1/2" No. 1995	28	7

2682877	D 19 VMU-10	reversible ratchet 1/2" No. 1993 U-10 T Socket wrench insert 1/2" 12-point UD profile No. D 19 10 11 12 13 14 15 16 17 18 19 20 21 22 23 24 26 27 28 30 32 33 34 36 Cross handle 1/2" No. 1987 Extension 1/2" No. 1990-5 -10 Cardan joint 1/2" No. 1995	28	6,7
----------------	-------------	---	----	-----

IN 19 Q
Screwdriver set 1/2"
11 pieces



12,5 1/2"

- > for in-hex screws
- > In GEDORE blue sheet steel case

Code	No.	Contents	Pieces	
6156920	IN 19 Q	reversible ratchet 1/2" No. 1993 U-10 T Screwdriver bit socket 1/2" for hexagon socket screws No. IN 19 5 6 7 8 9 10 12 14 17 Extension 1/2" No. 1990 -10	11	3,315

19 IMU / D 19 IMU

Socket set 1/2"
27 pieces

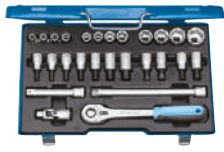

12,5 1/2"

- > With hand-operated 6-sided UD profile (No. 19) or 12-sided UD profile (No. D 19) sockets
- > With operating tools
- > With robust lever-change reversible ratchet, with push-button release
- > In GEDORE blue sheet steel case

Code	No.	Contents	Pieces	kg
6139750	19 IMU-10	reversible ratchet 1/2" No. 1993 U-10 T Socket wrench insert 1/2" hexagon UD profile No. 19 10 11 12 13 14 15 17 19 22 24 27 30 Screwdriver bit socket 1/2" for hexagon socket screws No. IN 19 5 6 7 8 10 12 14 Screwdriver bit socket 1/2" for slotted screws No. IS 19 8 10 Screwdriver bit socket 1/2" for cross-head screws PH No. IKS 19 2 3 Extension 1/2" No. 1990-5 -10 Cardan joint 1/2" No. 1995	27	6,9
6140090	D 19 IMU-10	reversible ratchet 1/2" No. 1993 U-10 T Socket wrench insert 1/2" 12-point UD profile No. D 19 10 11 12 13 14 15 17 19 22 24 27 30 Screwdriver bit socket 1/2" for hexagon socket screws No. IN 19 5 6 7 8 10 12 14 Screwdriver bit socket 1/2" for slotted screws No. IS 19 8 10 Screwdriver bit socket 1/2" for cross-head screws PH No. IKS 19 2 3 Extension 1/2" No. 1990-5 -10 Cardan joint 1/2" No. 1995	27	6,8

ITX 19 INU-20

Socket set 1/2"
42 pieces



12,5 1/2"

- > For inside and outside TX screws and hexagon socket screws
- > In GEDORE blue sheet steel case

Code	No.	Contents	Pieces	kg
2546000	ITX 19 INU-20	reversible ratchet 1/2" No. 1993 U-20 Socket wrench insert 1/2" hexagon UD profile No. 19 10 11 12 13 14 15 16 17 18 19 21 22 24 27 30 32 Screwdriver bit socket 1/2" for hexagon socket screws No. IN 19 5 6 7 8 9 10 12 14 17 Socket wrench socket 1/2" for external TX screws No. TX 19 E10 E12 E14 E16 E18 E20 E24 Screwdriver bit socket 1/2" for inside TX screws No. ITX 19 T20 T25 T27 T30 T40 T45 T50 T55 T60 Cardan extension No. 1990 KR-10	42	8,2

19 V20U-10

Socket set 1/4"+1/2"
50 pieces



12,5 1/2"

- > With hand operated sockets
- > With operating tools
- > Nominal size 6.3 (1/4") with extra fine-toothed reversible ratchet U-3
- > Nominal size 12.5 (1/2") with robust lever-operated reversible ratchet, with push-button release U-10 T
- > In GEDORE blue sheet steel case

Code	No.	Contents	Pieces	kg
6157490	19 V20 U-10	reversible ratchet 1/2" No. 1993 U-10 T Reversible ratchet 1/4" No. 2093 U-3 Socket wrench insert 1/2" hexagon No. 19 10 11 12 13 14 15 17 19 22 24 27 30 Screwdriver bit socket 1/2" for hexagon socket screws No. IN 19 7 8 10 12 14 Screwdriver bit socket 1/2" for slotted screws No. IS 19 8 10 Screwdriver bit socket 1/2" for cross-head screws PH No. IKS 19 3 Socket wrench insert 1/4" hexagon No. 20 4 4.5 5 5.5 6 7 8 9 10 11 13 Screwdriver bit socket 1/4" for hexagon socket screws No. IN 20 3 4 5 6 Screwdriver bit socket 1/4" for slotted screws No. IS 20 4 5 5 6 5 Screwdriver bit socket 1/4" for cross-head screws PH No. IKS 20 1 2 Extension 1/2" No. 1990-5 -10 Cardan joint 1/2" No. 1995 Square plug-in handle 1/4" No. 2098 Extension 1/4" No. 2090-2 -4 Cross handle 1/4" No. 2087 Cardan joint 1/4" No. 2095	50	6,2

19 V20U-20Socket set 1/4"+1/2"
81 pieces
12,5 1/2" 6,3 1/4"

- > With hand operated sockets
- > With operating tools
- > With robust lever-change reversible ratchet, with push-button release
- > In GEDORE blue sheet steel case

Code	No.	Contents	Pieces	
1550691	19 V20 U-20	reversible ratchet 1/2" No. 1993 U-20 Reversible ratchet 1/4" No. 2093 U-20 Socket wrench insert 1/2" hexagon UD profile No. 19 10 11 12 13 14 15 16 17 18 19 21 22 24 27 30 32 36 Socket wrench insert 1/4" 12-point UD profile No. D 20 4 5 5.5 6 7 8 9 10 11 12 13 Screwdriver bit 1/4" for slotted screws No. 680 4 4,5 5,5 6,5 Screwdriver bit 1/4" for hexagon socket screws No. 685 2 2.5 3 4 5 6 8 Screwdriver bit 1/4" for multi-tooth socket screws XZN No. 685 X 5 6 8 Screwdriver bit 1/4" for inside TX screws No. 687 TX T10 T15 T20 T25 T27 T30 T40 Screwdriver bit 1/4" for cross-head screws PH No. 690 1 2 3 Screwdriver bit 1/4" for cross-head screws PZ No. 690 PZD 1 2 3 Screwdriver bit 5/16" for slotted screws No. 885 3 4 5 6 8 10 Screwdriver bit 5/16" for multi-tooth socket screws XZN No. 885 X 5 6 8 10 12 Screwdriver bit 5/16" for inside TX screws No. 887 TX T27 T30 T40 T45 T50 Extension 1/2" No. 1990-5 -10 Extension 1/4" No. 2090-4 Multi-handle No. 676 Cardan joint 1/4" No. 2095 Bit adapter No. 620 Bit holder for machine screwdriver No. 699 Connecting piece 5/16" - 1/2 No. KB 819	81	6,3

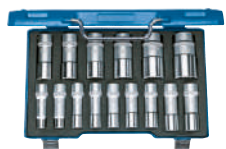
D 19 L-015Socket set 1/2"
15 pieces
12,5 1/2"

- > With hand operated 12-point UD profile sockets
- > In GEDORE blue sheet steel case

Code	No.	Contents	Pieces	
2190214	D 19 L-015	Socket wrench insert 1/2" 12-point UD profile, long No. D 19 L 10 12 13 14 15 16 17 18 19 21 22 24 27 30 32	15	4,3

IN 19-009Screwdriver set 1/2"
9 pieces
12,5 1/2"

- > Screwdriver set 1/2" for hexagon socket screws in sizes 4 - 14 mm
- > In a practical, robust plastic case
- > GEDORE Check-Tool-System: 2-colour foam insert to check that the set is complete

Code	No.	Contents	Pieces	
3014444	IN 19-009	Screwdriver bit socket 1/2" for hexagon socket screws No. IN 19 4 Screwdriver bit socket 1/2" for in-hex screws, long No. IN 19 L 5-90 6-90 7-140 8-140 9-140 10-140 12-140 14-140	9	1,9

IN 19 PMScrewdriver set 1/2"
9 pieces
12,5 1/2"

- > for in-hex screws
- > In GEDORE blue sheet steel case

Code	No.	Contents	Pieces	
6156250	IN 19 PM	Screwdriver bit socket 1/2" for hexagon socket screws No. IN 19 5 6 7 8 9 10 12 14 17	9	1,362

INX 19 PM

Screwdriver set 1/2"
9 pieces



12,5 1/2"

- > For cross-head, slotted and socket head screws
- > In GEDORE blue sheet steel case

Code	No.	Contents	Pieces	
6150050	INX 19 PM	Screwdriver bit socket 1/2" for recessed TX screws No. ITX 19 5 6 8 10 12 Screwdriver bit socket 1/2" for cross-head screws PH No. IKS 19 2 3 Screwdriver bit socket 1/2" for slotted screws No. IS 19 12 16	9	1,3

IN 19 LKM

Screwdriver set 1/2"
15 pieces

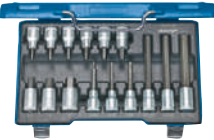

12,5 1/2"

- > for in-hex screws, short and long
- > In GEDORE blue sheet steel case

Code	No.	Contents	Pieces	
6129360	IN 19 LKM	Screwdriver bit socket 1/2" for hexagon socket screws No. IN 19 5 6 7 8 9 10 12 14 17 Screwdriver bit socket 1/2" for in-hex screws, long No. IN 19 L 5 6 8 10 12 14	15	3,2

ITX 19 PM

Screwdriver set 1/2"
9 pieces



12,5 1/2"

- > No. ITX 19 PM: for internal TX screws
- > In GEDORE blue sheet steel case

Code	No.	Contents	Pieces	
6158970	ITX 19 PM	Screwdriver bit socket 1/2" for inside TX screws No. ITX 19 T20 T25 T27 T30 T40 T45 T50 T55 T60	9	1,2

TX 19 E-09

Socket set 1/2"
9 pieces



12,5 1/2"

- > for protruding TX head screws
- > With convertor 3/8" to 1/2"
- > In plastic case

Code	No.	Contents	Pieces	
6265970	TX 19 E-09	Socket wrench socket 1/2" for external TX screws No. TX 19 E10 E11 E12 E14 E16 E18 E20 E24 Enlarging piece 3/8" to 1/2" No. 3019	9	1,036

ITX 19 TX-017

Screwdriver set 1/2"
17 pieces

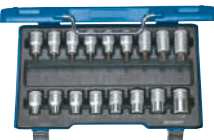

12,5 1/2"

- > For protruding and recessed TX screws
- > In GEDORE blue sheet steel case

Code	No.	Contents	Pieces	
6129520	ITX 19 TX-017	Screwdriver bit socket 1/2" for inside TX screws No. ITX 19 T20 T25 T27 T30 T40 T45 T50 T55 T60 Socket wrench socket 1/2" for external TX screws No. TX 19 E10 E11 E12 E14 E16 E18 E20 E24	17	2,99

ITX 19 LKP

Screwdriver set 1/2"
18 pieces



12,5 1/2"

- > for recessed TX screws, short and long
- > In GEDORE blue sheet steel case

Code	No.	Contents	Pieces	
6138510	ITX 19 LKP	Screwdriver bit socket 1/2" for inside TX screws No. ITX 19 T20 T25 T27 T30 T40 T45 T50 T55 T60 Screwdriver bit socket 1/2" for recessed TX screws, long No. ITX 19 L T20 T25 T27 T30 T40 T45 T50 T55 T60	18	3,2

19 TX 20
Screwdriver set
1/2" + 1/4"
34 pieces



6,3 1/4" 12,5 1/2"

- > Inserts 1/4" and 1/2", short and long, for inside and outside TX screws
- > In GEDORE blue sheet steel case

Code	No.	Contents	Pieces	kg
6129440	19 TX 20	Screwdriver bit socket 1/2" for inside TX screws No. ITX 19 T40 T45 T50 T55 T60 Screwdriver bit socket 1/2" for recessed TX screws, long No. ITX 19 LT20 T25 T27 T30 T40 T45 T50 T55 T60 Socket wrench socket 1/2" for external TX screws No. TX 19 E12 E14 E16 E18 E20 E24 Screwdriver bit socket 1/4" for recessed TX screws No. ITX 20 T8 T9 T10 T15 T20 T25 T27 T30 Socket wrench insert 1/4" for external TX screws No. TX 20 E4 E5 E6 E7 E8 E10	34	3,6

D 19 WAU-20
Socket set 1/2"
31 pieces



12,5 1/2"

- > With hand operated 12-point UD profile sockets
- > With operating tools
- > With robust lever-change reversible ratchet, with push-button release
- > In GEDORE blue sheet steel case

Code	No.	Contents	Pieces	kg
2546027	D 19 WAU-20	reversible ratchet 1/2" No. 1993 U-20 Socket wrench insert 1/2" 12-point UD profile No. D 19 5/16 11/32 3/8 13/32 7/16 1/2 9/16 9/32 5/8 11/16 3/4 25/32 13/16 7/8 5/16 1" 1.1/16 1.1/8 1.3/16 1.1/4 Offset screwdriver set long in holder 8 pcs AF No. H 42 EL-88 A Extension 1/2" No. 1990-5 -10 Cardan joint 1/2" No. 1995	31	5,9

IN 19 PA
Screwdriver set 1/2"
9 pieces



12,5 1/2"

- > for in-hex screws
- > In GEDORE blue sheet steel case

Code	No.	Contents	Pieces	kg
6156410	IN 19 PA	Screwdriver bit socket 1/2" for hexagon socket screws No. IN 19 3/16 7/32 1/4 9/32 5/16 3/8 1/2 9/16 5/8	9	1,328

D 19 XMAU-20
Socket set 1/2"
31 pieces



12,5 1/2"

- > With hand operated 12-point UD profile sockets
- > With operating tools
- > With robust lever-change reversible ratchet, with push-button release
- > In GEDORE blue sheet steel case

Code	No.	Contents	Pieces	kg
2546043	D 19 XMAU-20	reversible ratchet 1/2" No. 1993 U-20 Socket wrench insert 1/2" 12-point UD profile No. D 19 11 13 14 17 19 22 24 27 30 32 Socket wrench insert 1/2" 12-point UD profile No. D 19 3/8 13/32 7/16 1/2 9/16 19/32 5/8 11/16 3/4 25/32 13/16 7/8 15/16 1" 1.1/16 1.1/8 Cross handle 1/2" No. 1987 Extension 1/2" No. 1990-5 -10 Cardan joint 1/2" No. 1995	31	6,6

1985
Speed brace 1/2"



- > Acc. to DIN 3122, ISO 3315
- > For hand-operated sockets and accessories with square drive as per DIN 3120, ISO 1174, ball locking device

Code	No.	"	mm	mm	kg
6143350	1985	1/2"	12,5	395	0,619

1998
Swivel handle with sliding T 1/2"



- > For hand-operated sockets and accessories with square drive as per DIN 3120, ISO 1174, ball locking device

Code	No.	"	mm	mm	kg
6199730	1998	1/2"	12,5	460	0,747

1996 - 1997
Swivel handle 1/2"



- > Acc. to DIN 3122, ISO 3315
- > For hand-operated sockets and accessories with square drive as per DIN 3120, ISO 1174, ball locking device

Code	No.	"	mm	mm	kg
6144830	1996	1/2"	12,5	255	0,426
6144910	1997	1/2"	12,5	381	0,593

1987
Sliding T bar 1/2"



- > Acc. to DIN 3122, ISO 3315
- > For hand-operated sockets and accessories with square drive as per DIN 3120, ISO 1174, ball locking device

Code	No.	"	mm	mm	kg
6143430	1987	1/2"	12,5	292	0,386

1981 K
L-handle 1/2"



- > Acc. to DIN 3122, ISO 3315
- > For hand-operated sockets and accessories with square drive as per DIN 3120, ISO 1174, ball locking device

Code	No.	"	mm	mm	kg
6143270	1981 K	1/2"	12,5	220	0,267

1987 A
Sliding T bar with release 1/2"



- > Secured against unintentional removal
- > Simple locking and unlocking by turning the handle
- > Unintentional release during work is prevented by asymmetrical positioning of the release point
- > DBGM (German utility patent)

Code	No.	"	mm	mm	kg
1871641	1987 A	1/2"	12,5	292	0,375

1990
Extension 1/2"



- > Acc. to DIN 3123, ISO 3316
- > For hand-operated sockets and accessories with square drive as per DIN 3120, ISO 1174, ball locking device

Code	No.	"	mm	mm	kg
6143510	1990-2.1/2	1/2"	12,5	63	0,115
6143780	1990-3	1/2"	12,5	76	0,137
6143860	1990-5	1/2"	12,5	125	0,188
6142890	1990-7	1/2"	12,5	180	0,264
6143940	1990-10	1/2"	12,5	250	0,361
6129950	1990-12	1/2"	12,5	305	0,45

1990 A
Extension 1/2" with release



- > Easy access to deep-fitting screws in confined areas
- > No unintentional release due to safety ring
- > For hand-operated sockets and accessories with square drive as per DIN 3120, ISO 1174, ball locking device

Code	No.	"	mm	mm	kg
1640828	1990 A-5	1/2"	12,5	125	0,216
1640801	1990 A-10	1/2"	12,5	250	0,386

1990 KR

Universal extension 1/2"

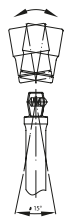

- > With ball end
- > For hand-operated sockets and accessories with square drive as per DIN 3120, ISO 1174, ball locking device
- > The extension is able to pivot up to 18°
- > Load capacity max. 230 N-m

Code	No.	"	mm	mm	kg
3128180	1990 KR-2	1/2"	12,5	50	0,08
6173180	1990 KR-5	1/2"	12,5	125	0,18
6225590	1990 KR-7	1/2"	12,5	180	0,255
6366570	1990 KR-10	1/2"	12,5	250	0,345

1990 M

Extension 1/2" with holding magnet



- > For hand-operated sockets with through hole and square drive according to DIN 3120, ISO 1174, with ball locking device
- > One-hand operation - the screw or nut can be screwed in immediately with the socket wrench insert
- > A strong permanent magnet keeps hold of even large screws
- > perfect for work in confined spaces

Code	No.	"	mm	mm	kg
2697920	1990 M	1/2"	12,5	81,5	0,11

i 1990 M

Universal extension with magnetic effect

The essentially plain-looking universal extension in combination, for instance, with the right sockets and socket drivers is transformed into our secret star.

YOUR ADVANTAGE

- Secure fixing even of large screws
- One-handed operation Using the socket, the screw can be immediately screwed in
- Powerful magnet with spring mechanism ensures centric screw guidance.
- Makes work easier particularly in confined spaces

TECHNOLOGY

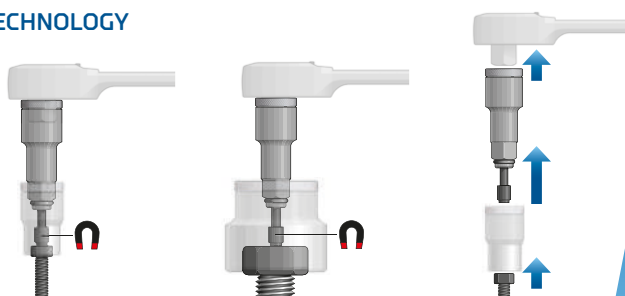

ONE-HAND OPERATION



1995
Universal joint 1/2"



- > Acc. to DIN 3123, ISO 3316
- > For hand-operated sockets and accessories with square drive as per DIN 3120, ISO 1174, ball locking device

Code	No.	□"	□ mm	■"	■ mm	↳ mm ▷	
6144750	1995	1/2"	12,5	1/2"	12,5	72	0,159

1994
Coupler 1/2"



- > Acc. to DIN 3122, ISO 3315
- > For hand-operated sockets and accessories with square drive as per DIN 3120, ISO 1174, ball locking device

Code	No.	■"	■ mm	↳ mm ▷	
6144670	1994	1/2"	12,5	38	0,045

1930
Reducer 1/2" to 3/8"



- > Acc. to DIN 3123, ISO 3316
- > For hand-operated sockets and accessories with square drive as per DIN 3120, ISO 1174, ball locking device

Code	No.	□"	□ mm	■"	■ mm	↳ mm ▷	
6143000	1930	1/2"	12,5	3/8"	10	38,5	0,062

1932
Convertor 1/2" to 3/4"



- > Acc. to DIN 3123, ISO 3316
- > For hand-operated sockets and accessories with square drive as per DIN 3120, ISO 1174, ball locking device

Code	No.	□"	□ mm	■"	■ mm	↳ mm ▷	
6143190	1932	1/2"	12,5	3/4"	20	44	0,128

SL 1916
Tool holding rail, magnetic 1/2" empty



- > 12 Outer square edge suitable for sockets nominal size 12.5 (1/2")
- > 2 inner square adaptors for ratchets, sliding handles, extensions etc.

- > A strong magnet securely holds the socket rail to ferrous metals
- > Delivery without sockets

Code	No.	Version	↳ mm ▷	mm	
1761102	SL 1916	for 16 pieces 1/2" inserts	580	33	0,522

VH 19
Spring steel socket rail 1/2"



12,5 1/2"

- > For 14 1/2" sockets
- > Delivery without tools

Code	No.	↳ mm	⚖️
5162520	VH 19	405	0,065

3293 U-10
Reversible ratchet 3/4"



3/4" 20

- > Acc. to DIN 3122, ISO 3315
- > With recessed lever change, locks in middle position
- > Return angle 11.25°
- > For hand-operated sockets and accessories with

square drive as per DIN 3120 - D 20, ISO 1174 with locking pin

Code	No.	■ "	■	∠ °	↳ mm	mm	⚖️
6277980	3293 U-10	3/4"	20	11,25	620	57,5	2,63

3293 U-2
Reversible ratchet 3/4"



3/4" 20

- > Acc. to DIN 3122, ISO 3315
- > With disc change, fine-toothed and robust
- > Return angle 7.2°

> For hand-operated sockets and accessories with square drive as per DIN 3120 - D 20, ISO 1174 with locking pin

Code	No.	■ "	■	∠ °	↳ mm	mm	⚖️
6278600	3293 U-2	3/4"	20	7,2	510	60	1,435

3293 U-3
Reversible ratchet 3/4"



3/4" 20

- > Acc. to DIN 3122, ISO 3315
- > With non-slip metal disc change, fine-toothed (72 teeth) and robust
- > Return angle 5°

> For hand-operated sockets and accessories with square drive as per DIN 3120 - D 20, ISO 1174 with locking pin

Code	No.	■ "	■	∠ °	↳ mm	mm	⚖️
6278790	3293 U-3	3/4"	20	5	620	62,5	2,61

3293 Z-94
Ratchet handle 3/4"



3/4" 20

- > Acc. to DIN 3122, ISO 3315
- > With square coupler, medium-fine toothed, extremely rugged
- > Return angle 10°

> For hand-operated sockets and accessories with square drive as per DIN 3120 - D 20, ISO 1174 with locking pin

Code	No.	■ "	■	∠ °	↳ mm	mm	⚖️
6278950	3293 Z-94	3/4"	20	10	510	31	1,301

32
Socket 3/4"
hexagon UD profile

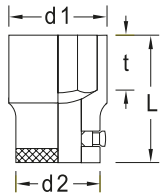

20 **3/4"**

- > Acc. to DIN 3124, ISO 2725-1
- > Square drive as per DIN 3120 - D 20, ISO 1174, with locking pin
- > Hand-operated

*** not standardised**

Code	No.	mm	L	d1	d2	t	kg
6269880*	32 18	18	51,5	28,3	36,0	19,0	0,219
6270110*	32 19	19	51,5	29,6	36,0	19,0	0,225
6269960	32 21	21	51,5	32,0	36,0	19,0	0,228
6270380	32 22	22	51,5	33,3	36,0	19,0	0,232
6270460	32 24	24	51,5	35,8	38,0	19,5	0,267
6270540	32 27	27	54,5	39,6	36,0	24,0	0,271
6270700	32 30	30	57,5	43,3	38,0	26,0	0,331
6270890	32 32	32	57,5	45,8	38,0	27,0	0,345
6270030*	32 33	33	57,5	47,0	40,0	26,5	0,392
6279410	32 34	34	57,5	48,3	40,0	26,5	0,404
6270970	32 36	36	59,5	50,8	40,0	28,0	0,448
6271000*	32 38	38	59,5	53,3	40,5	28,0	0,476
6271190	32 41	41	62,5	57,1	44,0	30,5	0,593
6271270	32 46	46	65,5	63,3	44,0	32,5	0,7
6271350	32 50	50	68,5	68,3	48,0	34,5	0,848
6271430	32 55	55	68,5	74,6	53,0	33,0	1,008
6271510	32 60	60	68,5	80,8	53,0	33,0	1,143

D 32 (MM)
Socket 3/4"
Bi-hexagon UD profile

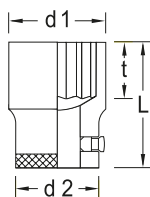

20 **3/4"**

- > Acc. to DIN 3124, ISO 2725-1
- > Square drive as per DIN 3120 - D 20, ISO 1174, with locking pin
- > Hand-operated

*** not standardised**

Code	No.	mm	L	d1	d2	t	kg
6272160*	D 32 19	19	51,5	36,0	29,6	19,0	0,221
6289800	D 32 21	21	51,5	36,0	32,0	19,0	0,223
6272240	D 32 22	22	51,5	36,0	33,3	19,0	0,227
6272320	D 32 24	24	51,5	38,0	35,8	19,5	0,257
6272400	D 32 27	27	54,5	36,0	39,6	24,0	0,255
6272670	D 32 30	30	57,5	38,0	43,3	26,0	0,319
6272750	D 32 32	32	57,5	38,0	45,8	27,0	0,332
6272830	D 32 36	36	59,5	40,0	50,8	28,0	0,418
6272910*	D 32 38	38	59,5	40,5	53,3	28,0	0,441
6273050	D 32 41	41	62,5	44,0	57,1	30,5	0,5
6273130	D 32 46	46	65,5	44,0	63,3	32,5	0,641
6273210	D 32 50	50	68,5	48,0	68,3	34,5	0,8
6273480	D 32 55	55	68,5	53,0	74,6	33,0	0,961
6273560	D 32 60	60	68,5	53,0	80,8	33,0	1,052

D 32 (AF)
Socket 3/4"
Bi-hexagon UD profile

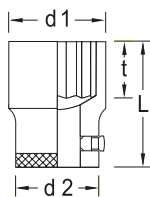

20 **3/4"**

- > Square drive as per DIN 3120 - D 20, ISO 1174, with locking pin
- > Hand-operated

Code	No.	mm	L	d1	d2	t	kg
6274020	D 32 7/8AF	7/8"	51,5	36,0	33,6	19,0	0,227
6274100	D 32 15/16AF	15/16"	51,5	38,0	35,6	19,5	0,262
6274290	D 32 1AF	1"	51,5	36,0	37,6	22,0	0,229
6274370	D 32 1.1/16AF	1.1/16"	54,5	36,0	39,6	24,0	0,256
6274450	D 32 1.1/8AF	1.1/8"	54,5	36,0	41,5	24,0	0,268
6274530	D 32 1.1/4AF	1.1/4"	57,5	38,0	45,5	27,0	0,333
6274610	D 32 1.5/16AF	1.5/16"	57,5	40,0	47,5	26,5	0,377
6274880	D 32 1.3/8AF	1.3/8"	59,5	40,0	49,5	28,0	0,407
6274960	D 32 1.7/16AF	1.7/16"	59,5	40,0	51,4	28,0	0,413
6275180	D 32 1.1/2AF	1.1/2"	59,5	40,5	53,3	28,0	0,431
6275260	D 32 1.5/8AF	1.5/8"	62,5	44,0	57,4	30,5	0,539
6275340	D 32 1.11/16AF	1.11/16"	62,5	44,0	59,4	30,5	0,568
6275420	D 32 1.3/4AF	1.3/4"	65,5	44,0	61,4	32,5	0,627
6275500	D 32 1.13/16AF	1.13/16"	65,5	44,0	63,3	32,5	0,637
6275690	D 32 1.7/8AF	1.7/8"	65,5	44,0	65,3	32,5	0,664
6275770	D 32 2AF	2"	68,5	48,0	69,2	34,5	0,811

IN 32
Screwdriver
bit socket 3/4"
for in-hex screws,
long pattern

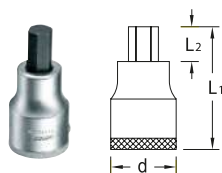

20 3/4"

- > Acc. to DIN 7422
- > Square drive as per DIN 3120 - D 20, ISO 1174, with locking pin
- > Hand-operated

Code	No.	mm	L1	L2	d	kg
6275850	IN 32 14	14	80	25,5	38	0,352
6275930	IN 32 17	17	80	25,5	38	0,394
6276070	IN 32 19	19	80	25,5	38	0,433
6276150	IN 32 22	22	80	25,5	38	0,482

IN 32 L
Screwdriver
bit socket 3/4"
for in-hex screws,
long pattern

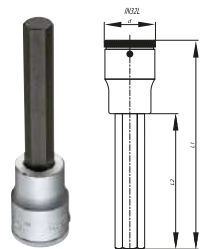

20 3/4"

- > Acc. to DIN 7422
- > Square drive as per DIN 3120 - D 20, ISO 1174, with locking pin
- > Hand-operated

Code	No.	mm	L1	L2	d	kg
2003503	IN 32 L 14-155	14	155	100,0	38	0,452
1353705	IN 32 L 17-155	17	155	100,0	38	0,54
2003511	IN 32 L 19-155	19	155	100,0	38	0,61
2003538	IN 32 L 22-155	22	155	100,0	38	0,73

ITX 32
Screwdriver
bit socket 3/4"
for recessed
TX screws, short



20 3/4"

- > Square drive as per DIN 3120 - D 20, ISO 1174, with locking pin
- > Hand-operated

Code	No.		M	mm	L1	L2	d	kg
6271780	ITX 32 T60	T60	M14	13,25	80	25,5	38	0,346
6272080	ITX 32 T70	T70	M16	15,55	80	25,5	38	0,383
6273640	ITX 32 T80	T80	M18	17,58	80	25,5	38	0,416
6276230	ITX 32 T90	T90	M20	19,95	80	26,0	38	0,455
6276310	ITX 32 T100	T100	M14	21,16	80	25,5	38	0,461

3296
Swivel handle 3/4"



- > Acc. to DIN 3122, ISO 3315
- > For hand-operated sockets and accessories with square drive as per DIN 3120, ISO 1174 with locking pin

Code	No.	"	mm	mm	kg
6279250	3296	3/4"	20	547	1,965

3287
Sliding T bar 3/4"



- > Acc. to DIN 3122, ISO 3315
- > For hand-operated sockets and accessories with square drive as per DIN 3120, ISO 1174 with locking pin

Code	No.	"	mm	mm	kg
6278360	3287	3/4"	20	500	1,161

3290
Extension 3/4"



- > Acc. to DIN 3123, ISO 3316
- > For hand-operated sockets and accessories with square drive as per DIN 3120, ISO 1174 with locking pin

Code	No.	■ "	■ mm	↳ mm	⚖
6278440	3290-8	3/4"	20	200	0,574
6278520	3290-16	3/4"	20	400	1,079

3295
Universal joint 3/4"



- > Acc. to DIN 3123, ISO 3316
- > For hand-operated sockets and accessories with square drive as per DIN 3120, ISO 1174 with locking pin

Code	No.	□ "	□ mm	■ "	■ mm	↳ mm	⚖
6279170	3295	3/4"	20,0	3/4"	20	108	0,58

3294
Coupler 3/4"



- > Acc. to DIN 3122, ISO 3315
- > For hand-operated sockets and accessories with square drive as per DIN 3120, ISO 1174 with locking pin

Code	No.	■ "	■ mm	↳ mm	⚖
6279090	3294	3/4"	20	51,5	0,133

3219
Reducer 3/4" to 1/2"



- > Acc. to DIN 3123, ISO 3316
- > For hand-operated sockets and accessories with square drive as per DIN 3120, ISO 1174 with locking pin

Code	No.	□ "	□ mm	■ "	■ mm	↳ mm	⚖
6278010	3219	3/4"	20,0	1/2"	12,5	56	0,168

3221
Convertor 3/4" to 1"



- > Acc. to DIN 3123, ISO 3316
- > For hand-operated sockets and accessories with square drive as per DIN 3120, ISO 1174 with locking pin

Code	No.	□ "	□ mm	■ "	■ mm	↳ mm	⚖
6278280	3221	3/4"	20,0	1"	25	60	0,337

D 32 EA
 Socket set 3/4"
 14 pieces

20 **3/4"**

- > With hand operated 12-point UD profile sockets
- > With operating tools
- > Set U-2 with fine toothed, dial change ratchet
- > Set Z-94 with ratchet with square coupler
- > In GEDORE blue sheet steel case

Code	No.	Contents	Pieces	
6280690	D 32 EAU-2	reversible ratchet 3/4" No. 3293 U-2 Socket wrench insert 3/4" 12-edged UD profile No. D 32 15/16 1.1/16 1.1/8 1.1/4 1.5/16 1.3/8 1.1/2 1.5/8 1.7/8 2 Cross handle 3/4" No. 3287 Extension 3/4" No. 3290-8 -16	14	11,265

D 32 EMAU-2
 Socket set 3/4"
 25 pieces

20 **3/4"**

- > With hand operated 12-point UD profile sockets
- > With operating tools
- > With fine toothed, dial change ratchet
- > In GEDORE blue sheet steel case

Code	No.	Contents	Pieces	
6281310	D 32 EMAU-2	reversible ratchet 3/4" No. 3293 U-2 Socket wrench insert 3/4" 12-point UD profile No. D 32 22 24 27 30 32 36 41 46 50 Socket wrench insert 3/4" 12-point UD profile No. D 32 7/8 15/16 1" 1.1/16 1.1/8 1.1/4 1.5/16 1.3/8 1.1/2 1.11/16 1.7/8 2" Cross handle 3/4" No. 3287 Extension 3/4" No. 3290-8 -16	25	18,17

32 EM / D 32 EM
 Socket set 3/4"
 14 pieces

20 **3/4"**

- > With hand operated hexagonal (No. 32) or 12-point UD profile (No. D 32) Sockets
- > With operating tools
- > Set U-2 with fine toothed, dial change ratchet
- > Set Z-94 with ratchet with square coupler
- > In GEDORE blue sheet steel case

Code	No.	Contents	Pieces	
6280180	32 EMZ	Ratchet 3/4" No. 3293 Z-94 Socket wrench insert 3/4" hexagon UD profile No. 32 22 24 27 30 32 36 38 41 46 50 Cross handle 3/4" No. 3287 Extension 3/4" No. 3290-8 -16	14	11,4
6280340	32 EMU-2	reversible ratchet 3/4" No. 3293 U-2 Socket wrench insert 3/4" hexagon UD profile No. 32 22 24 27 30 32 36 38 41 46 50 Cross handle 3/4" No. 3287 Extension 3/4" No. 3290-8 -16	14	11,6
6280420	D 32 EMU-2	reversible ratchet 3/4" No. 3293 U-2 Socket wrench insert 3/4" 12-point UD profile No. D 32 22 24 27 30 32 36 38 41 46 50 Cross handle 3/4" No. 3287 Extension 3/4" No. 3290-8 -16	14	11,09

32 FM / D 32 FM
 Socket set 3/4"
 16 pieces

20 **3/4"**

- > With hand operated hexagonal (No. 32) or 12-point UD profile (No. D 32) Sockets
- > With operating tools
- > Set U-2 with fine toothed, dial change ratchet
- > Set Z-94 with ratchet with square coupler
- > In GEDORE blue sheet steel case

Code	No.	Contents	Pieces	
6280930	32 FMZ	Ratchet 3/4" No. 3293 Z-94 Socket wrench insert 3/4" 12-point UD profile No. 32 22 24 27 30 32 36 38 41 46 50 55 60 Cross handle 3/4" No. 3287 Extension 3/4" No. 3290-8 -16	16	15,6
6281150	32 FMU-2	reversible ratchet 3/4" No. 3293 U-2 Socket wrench insert 3/4" hexagon UD profile No. 32 22 24 27 30 32 36 38 41 46 50 55 60 Cross handle 3/4" No. 3287 Extension 3/4" No. 3290-8 -16	16	15,8
6281230	D 32 FMU-2	reversible ratchet 3/4" No. 3293 U-2 Plug-in key insert 3/4" 12-point UD profile No. D 32 2 22 24 27 30 32 36 38 41 46 50 55 60 Cross handle 3/4" No. 3287 Extension 3/4" No. 3290-8 -16	16	15,2

D 21 EMU-10

Socket set 1"
15 pieces



25 1"

- > With hand operated 12-point UD profile sockets
- > With operating tools
- > With robust lever-change reversible ratchet
- > In GEDORE blue sheet steel case

Code	No.	Contents	Pieces	
6181600	D 21 EMU-10	Reversible ratchet head 1" No. 2193 U-10 K Socket wrench insert 1" 12-point UD profile No. D 21 36 41 46 50 55 60 65 65 70 75 80 Extension 1" No. 2190-8 -16 Cross handle 1" No. 2187 G 2187 K	15	32,8

2193 U-10

Reversible ratchet 1"



1" 25

- > Acc. to DIN 3122, ISO 3315
- > With recessed lever change, locks in middle position
- > Return angle 11,25°
- > For hand-operated sockets and accessories with

square drive as per DIN 3120 - D 25, ISO 1174 with locking pin

Code	No.	"	"	°	mm	mm	
6180550	2193 U-10	1"	25	11,25	810	61,5	5,21

2193 U-3

Reversible ratchet 1"



1" 25

- > Acc. to DIN 3122, ISO 3315
- > With non-slip metal, fine-toothed (72 teeth) and robust
- > Return angle 5°

> For hand-operated sockets and accessories with square drive as per DIN 3120 - D 25, ISO 1174 with locking pin

Code	No.	"	"	°	mm	mm	
6180630	2193 U-3	1"	25	5	720	76	4,16
1637487	2193 U-3 K	1"	25	5	200	76	2

2193 Z-94

Ratchet handle 1"



1" 25

- > Acc. to DIN 3122, ISO 3315
- > With square coupler, medium-fine toothed, extremely rugged
- > Return angle 9°

> For hand-operated sockets and accessories with square drive as per DIN 3120 - D 25, ISO 1174 with locking pin

Code	No.	"	"	°	mm	mm	
6181520	2193 Z-94	1"	25	9	720	41	4,115

D 21 (MM)

Socket 1"
Bi-hexagon
UD profile

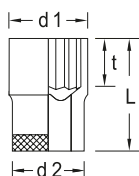

25 1"

- > Acc. to DIN 3124, ISO 2725-1
- > Square drive as per DIN 3120 - D 25, ISO 1174, with locking pin
- > Hand-operated

*** not standardised**

Code	No.		L	d1	d2	t	
6174900*	D 21 36	36	70	48,0	53,9	30,0	0,6
6175040	D 21 41	41	70	50,0	60,1	30,5	0,688
6175120	D 21 46	46	75	50,0	66,4	33,5	0,842
6175200	D 21 50	50	75	50,0	71,4	35,0	0,908
6175390	D 21 55	55	80	50,0	77,6	37,5	1,129
6175470	D 21 60	60	85	50,0	83,9	41,0	1,376
6175550	D 21 65	65	88	59,5	90,1	44,5	1,7
6175630	D 21 70	70	92	59,5	96,4	48,0	1,984
6175710	D 21 75	75	95	59,5	102,6	51,0	2,225
6175980	D 21 80	80	97	59,5	108,9	54,0	2,454

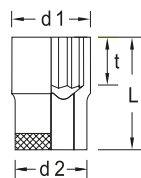
D 21 (AF)
 Socket 1"
 bi-hexagon

25 **1"**

- › Square drive as per DIN 3120 - D 25, ISO 1174, with locking pin
- › Hand-operated

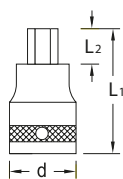
Code	No.		L	d1	d2	t	
6176520	D 21 1.1/2AF	1.1/2"	70	48,0	56,5	30,0	0,649
6176600	D 21 1.5/8AF	1.5/8"	70	50,0	60,1	30,5	0,701
6176870	D 21 1.13/16AF	1.13/16"	75	50,0	66,4	33,5	0,835
6176950	D 21 1.7/8AF	1.7/8"	75	50,0	68,4	33,5	0,89
6177090	D 21 2AF	2"	75	50,0	72,4	35,0	0,944
6177170	D 21 2.1/16AF	2.1/16"	75	50,0	74,0	35,0	0,987
6177250	D 21 2.3/16AF	2.3/16"	80	50,0	78,3	37,5	1,181
6177330	D 21 2.1/4AF	2.1/4"	80	50,0	80,3	37,5	1,23
6177410	D 21 2.3/8AF	2.3/8"	85	50,0	83,9	41,0	1,398
6177680	D 21 2.7/16AF	2.7/16"	85	50,0	86,2	41,0	1,544
6177760	D 21 2.9/16AF	2.9/16"	88	59,5	90,1	44,5	1,788
6177840	D 21 2.5/8AF	2.5/8"	88	59,5	92,2	44,5	1,813
6177920	D 21 2.3/4AF	2.3/4"	92	59,5	96,4	48,0	2,065
6178060	D 21 2.13/16AF	2.3/16"	92	59,5	98,2	48,0	2,14
6178140	D 21 2.15/16AF	2.15/16"	95	59,5	102,6	51,0	2,307
6178220	D 21 3AF	3"	95	59,5	104,1	51,0	2,349
6178300	D 21 3.1/8AF	3.1/8"	97	59,5	108,9	54,0	2,556

IN 21
 Screwdriver
 bit socket 1"
 for in-hex screws

25 **1"**

- › Acc. to DIN 7422
- › Square drive as per DIN 3120 - D 25, ISO 1174, with locking pin
- › Hand-operated

*** not standardised**

Code	No.		L1	L2	d	
6181010	IN 21 17	17	90	25,5	48	0,613
6181280	IN 21 19	19	90	25,5	48	0,676
6181360	IN 21 22	22	90	25,5	48	0,733
6181440	IN 21 24	24	90	25,5	48	0,784
6200680*	IN 21 27	27	90	25,5	48	0,856

2187
 Sliding T bar 1"

- › Acc. to DIN 3122, ISO 3315
- › For hand-operated sockets and accessories with square drive as per DIN 3120, ISO 1174 with locking pin

Code	No.				
6180120	2187	1"	25	700	3,955

2190
 Extension 1"

- › Acc. to DIN 3123, ISO 3316
- › For hand-operated sockets and accessories with square drive as per DIN 3120, ISO 1174 with locking pin

Code	No.				
6180200	2190-8	1"	25	200	1,182
6180390	2190-16	1"	25	400	2,144

2195
 Universal joint 1"

- › For hand-operated sockets and accessories with square drive as per DIN 3120, ISO 1174 with locking pin

Code	No.						
6180980	2195	1"	25,0	1"	25	140	1,482

2194
Coupler 1"



- > Acc. to DIN 3122, ISO 3315
- > For hand-operated sockets and accessories with square drive as per DIN 3120, ISO 1174 with locking pin

Code	No.	□"	□ mm	↳ mm	kg
6180710	2194	1"	25	67,5	0,321

2132
Reducer 1" to 3/4"



- > Acc. to DIN 3123, ISO 3316
- > For hand-operated sockets and accessories with square drive as per DIN 3120, ISO 1174 with locking pin

Code	No.	□"	□ mm	□"	□ mm	↳ mm	kg
6180040	2132	1"	25,0	3/4"	20	75	0,504

31 KR
Friction ratchet handle with insert ring
UD profile or bi-hexagon

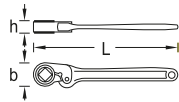

- > Friction key (No. 31 K) with exchangeable insert rings (No. 31 R)
- > Especially suitable for steel and scaffolding construction

- > Up to 30" flat shaft, from 35" with slip-on tube
- > Explanation of the article number: 31 KR 16-32 = ratchet 31 K 16" and insert ring 31 R 32 mm

Code	No.	○	L	L"	h	b	kg
6254850	31 KR 12-24	24	305	12	18,5	44,6	0,497
6255150	31 KR 12-27	27	305	12	18,5	44,6	0,474
6255230	31 KR 12-28	28	305	12	18,5	44,6	0,466
6255580	31 KR 16-30	30	19,5	16	19,5	51,6	0,709
6255740	31 KR 16-32	32	400	16	19,5	51,6	0,684
6256120	31 KR 20-36	36	500	20	21,5	63,6	1,162
6256470	31 KR 20-41	41	500	20	21,5	63,6	1,098
6256550	31 KR 25-46	46	635	25	31,5	78,1	2,302
6256630	31 KR 25-50	50	635	25	31,5	78,1	2,213
6256710	31 KR 30-55	55	760	30	33,5	92,0	3,011
6256980	31 KR 30-60	60	760	30	33,5	92,0	2,879
6257010	31 KR 35-65	65	940	35	36,5	105,0	7,204
6257440	31 KR 40-80	80	960	40	39,5	118,0	7,392

31 K
Friction ratchet handle without insert ring

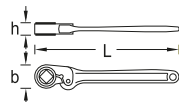

- > Friction spanner for insert rings 31 R and 31 VR



- > Especially suitable for steel and scaffolding construction

Code	No.	○	L	L"	Head Ø	kg
6243300	31 K 12	24-28	305	12	40	0,406
6243490	31 K 16	30-32	400	16	46	0,6
6243570	31 K 20	34-41	500	20	57	0,961
6243650	31 K 25	46-50	635	25	70	1,88
6243730	31 K 30	46-50	760	30	82	2,435
6243810	31 K 35	65-70	940	35	96	6,305
6244030	31 K 40	75-80	960	40	108	6,48

31 R
Insert ring
for friction ratchet
UD profile or
bi-hexagon



> Vanadium steel 31CrV3,
manganese-phosphated

Code	No.	⊙	∅		
6245270	31 R 10	10	19,7	6	0,018
6245510	31 R 13	13	19,7	6	0,011
6245780	31 R 14	14	27,6	8	0,047
6245860	31 R 15	15	27,6	8	0,044
6246160	31 R 18	18	33,6	10	0,075
6246400	31 R 21	21	33,6	10	0,059
6246750	31 R 24	24	39,6	12	0,091
6246910	31 R 26	26	39,6	12	0,076
6247050	31 R 27	27	39,6	12	0,069
6247130	31 R 28	28	39,6	12	0,061
6247480	31 R 30	30	45,6	16	0,109
6247640	31 R 32	32	45,6	16	0,084
6248020	31 R 36	36	56,6	20	0,201
6248370	31 R 41	41	56,6	20	0,137
6248450	31 R 46	46	70,0	25	0,422
6248530	31 R 50	50	70,0	25	0,333
6248610	31 R 55	55	82,0	30	0,576
6248880	31 R 60	60	82,0	30	0,444
6248960	31 R 65	65	96,0	35	0,899
6249180	31 R 70	70	96,0	35	0,718
6249260	31 R 75	75	108,0	40	1,163
6249340	31 R 80	80	108,0	40	0,912

29
Construction ratchet
bi-hexagon

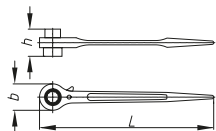



> reversible ratchet with
2 width across flats,
double hexagon, and
centre point
> Especially suitable for
steel and scaffolding
construction

Code	No.	⊙	L	h	b	
1648934	29 17X19	17 x 19	315	49	42,0	0,463
1382853	29 19X22	19 x 22	315	49,5	42,0	0,448
1648926	29 19X24	19 x 24	365	56	51,5	0,757
6262790	29 24X30	24 x 30	402	63	61,0	1,378
6262950	29 27X32	27 x 32	402	63	61,0	1,278
6263170	29 36X41	36 x 41	495	74	76,0	1,377

41 - 41 B
Reversible-ratchet





> With permanently fixed
UD profile insert

Code	No.	⊙	∠°	mm 	- mm	
6338950	41 27	27	11,25	27,9	620	2,41
6339170	41 30	30	11,25	27,9	620	2,365
6339250	41 32	32	11,25	27,9	620	2,33
6338360	41 B 36	36	15	43	910	5,025
6338440	41 B 41	41	15	43	910	4,895
6338520	41 B 46	46	15	43	910	4,725

41 V - 41 BV
Reversible-ratchet



> With permanently fixed
square insert
> Especially suitable for
steel and scaffolding
construction

Code	No.	⊙	∠°	mm 	- mm	
6339410	41 V 19	19	11,25	27,9	620	2,475
6339680	41 V 22	22	11,25	27,9	620	2,45
6339760	41 V 24	24	11,25	27,9	620	2,42
6339840	41 V 27	27	11,25	27,9	620	2,385
6338600	41 BV 30	30	15	43	910	5,115
6339330	41 BV 32	32	15	43	910	5,075
6339920	41 BV 36	36	15	43	910	4,97

K 20 (MM)
Impact socket 1/4"
hexagon

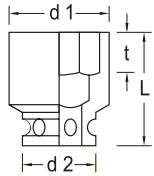

6,3 1/4"

- > Acc. to DIN 3129, ISO 2725-2
- > Machine-operated
- > Square drive as per DIN 3121 - G 6,3, ISO 1174

* not standardised

Code	No.	mm	L	d1	d2	t	Recommended accessories	kg
6198090	K 20 5,5	5,5	23,0	9,5	13,0	3,0	KB 2070, KB 2075	0,016
6198170	K 20 6	6	23,0	10,0	13,0	3,0	KB 2070, KB 2075	0,016
6198250	K 20 7	7	23,0	11,3	13,0	3,0	KB 2070, KB 2075	0,016
6198330	K 20 8	8	23,0	12,5	13,0	4,0	KB 2070, KB 2075	0,016
6198410	K 20 9	9	23,0	13,8	13,0	4,0	KB 2070, KB 2075	0,017
6198680	K 20 10	10	23,0	15,0	13,0	5,0	KB 2070, KB 2075	0,018
6198760	K 20 11	11	23,0	16,3	13,0	5,0	KB 2070, KB 2075	0,02
6198840	K 20 12	12	23,0	17,0	13,0	6,0	KB 2070, KB 2075	0,023
6198920	K 20 13	13	23,0	18,8	13,0	6,0	KB 2070, KB 2075	0,024
6199060*	K 20 14	14	25,0	20,0	13,0	7,0	KB 2070, KB 2075	0,02
6199140*	K 20 17	17	26,0	23,8	13,0	7,0	KB 2070, KB 2075	0,037

K 20 (AF)
Impact socket 1/4"
hexagon

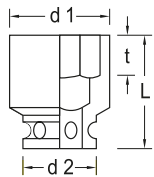

6,3 1/4"

- > Machine-operated
- > Square drive as per DIN 3121 - G 6,3, ISO 1174

Code	No.	AF	L	d1	d2	t	Recommended accessories	kg
6199220	K 20 3/16AF	3/16"	23,0	8,5	13,0	3,0	KB 2070, KB 2075	0,015
6199300	K 20 1/4AF	1/4"	23,0	10,3	13,0	3,0	KB 2070, KB 2075	0,017
6199490	K 20 5/16AF	5/16"	23,0	12,5	13,0	3,0	KB 2070, KB 2075	0,016
6199570	K 20 3/8AF	3/8"	23,0	15,0	13,0	4,0	KB 2070, KB 2075	0,018
6199650	K 20 7/16AF	7/16"	23,0	16,3	13,0	6,0	KB 2070, KB 2075	0,021

KB 2070
Retaining ring for
impact sockets 1/4"



Code	No.	Designation	Ø	kg
6200920	KB 2070	Retaining ring d 9 mm	9,0	0,005

KB 2075
Safety pin for
impact sockets 1/4"



Code	No.	Designation	Ø	mm	kg
6201060	KB 2075	Safety pin d 1,5 mm	1,5	10	0,005

KB 2090
Extension 1/4"
for impact sockets



- > With square drive as per DIN 3121 - G 6,3, ISO 1174

Code	No.	"	mm	mm	kg
6201140	KB 2090-2	1/4"	6,3	50	0,026

K 30
Impact socket 3/8"
hexagon

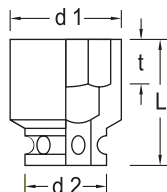

- > Acc. to DIN 3129, ISO 2725-2
- > Machine-operated
- > Square drive as per DIN 3121 - G 10, ISO 1174

* not standardised

Code	No.	mm	L	d1	d2	t	Recommended accessories	kg
6251160*	K 30 6	6	30,0	11,0	19,0	3,0	KB 3070 6-12, KB 3075 6-12	0,045
6251240	K 30 7	7	30,0	12,5	19,0	3,0	KB 3070 6-12, KB 3075 6-12	0,046
6251320	K 30 8	8	30,0	14,5	19,0	4,0	KB 3070 6-12, KB 3075 6-12	0,046
6251400	K 30 9	9	30,0	15,0	19,0	4,0	KB 3070 6-12, KB 3075 6-12	0,046
6251590	K 30 10	10	30,0	16,0	19,0	5,0	KB 3070 6-12, KB 3075 6-12	0,046
6251670	K 30 11	11	30,0	17,5	19,0	5,0	KB 3070 6-12, KB 3075 6-12	0,046
6251750	K 30 12	12	30,0	19,0	19,0	6,0	KB 3070 6-12, KB 3075 6-12	0,046
6251830	K 30 13	13	30,0	19,0	22,0	6,0	KB 3070 13-24, KB 3075 13-24	0,063
6251910	K 30 14	14	30,0	21,0	22,0	7,0	KB 3070 13-24, KB 3075 13-24	0,063
6252050	K 30 15	15	30,0	22,0	22,0	7,0	KB 3070 13-24, KB 3075 13-24	0,062
6252130	K 30 16	16	30,0	24,0	22,0	8,0	KB 3070 13-24, KB 3075 13-24	0,066
6252210	K 30 17	17	30,0	25,0	22,0	9,0	KB 3070 13-24, KB 3075 13-24	0,068
6252480	K 30 18	18	30,0	26,0	22,0	9,0	KB 3070 13-24, KB 3075 13-24	0,075
6252560	K 30 19	19	30,0	27,5	22,0	9,5	KB 3070 13-24, KB 3075 13-24	0,076
6252640*	K 30 20	20	30,0	28,0	22,0	10,0	KB 3070 13-24, KB 3075 13-24	0,084
6252720*	K 30 21	21	30,0	30,0	22,0	11,0	KB 3070 13-24, KB 3075 13-24	0,089
6252800*	K 30 22	22	30,0	32,0	23,0	11,0	KB 3070 13-24, KB 3075 13-24	0,093
6252990*	K 30 23	23	30,0	32,0	23,0	13,0	KB 3070 13-24, KB 3075 13-24	0,095
6254420*	K 30 24	24	30,0	35,0	23,0	13,0	KB 3070 13-24, KB 3075 13-24	0,105

TX K 30
Impact socket 3/8"
for protruding TX
head screws

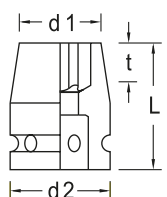

- > Machine-operated
- > Square drive as per DIN 3121 - G 10, ISO 1174

Code	No.	mm	M	mm	L	d1	d2	t	Recommended accessories	kg
6265030	TX K 30 E5	E5	M4	4,73	32,0	9,0	19,0	5,0	KB 3070 6-12, KB 3075 6-12	0,042
6265110	TX K 30 E6	E6	M5	5,74	32,0	10,0	19,0	5,0	KB 3070 6-12, KB 3075 6-12	0,044
6265380	TX K 30 E7	E7	M6	6,16	32,0	10,0	19,0	7,0	KB 3070 6-12, KB 3075 6-12	0,044
6265460	TX K 30 E8	E8	M6-M7	7,52	32,0	10,5	19,0	8,0	KB 3070 6-12, KB 3075 6-12	0,048
6265540	TX K 30 E10	E10	M8	9,42	32,0	12,5	19,0	9,0	KB 3070 6-12, KB 3075 6-12	0,048
6265620	TX K 30 E12	E12	M10	11,17	32,0	15,0	19,0	10,0	KB 3070 6-12, KB 3075 6-12	0,047
6265700	TX K 30 E14	E14	M12	12,9	32,0	19,0	19,0	12,0	KB 3070 6-12, KB 3075 6-12	0,046

KB 3095
Universal joint 3/8"
for impact sockets



> With square drive as per DIN 3121 - G 10, ISO 1174

Code	No.	□"	□ mm	■"	■ mm	↳ mm	kg
6262440	KB 3095	3/8"	10,0	3/8"	10	50	0,072

KB 3020
Reducer 3/8" to 1/4"
for impact sockets



> With square drive as per DIN 3121 - G 10, ISO 1174

Code	No.	□"	□ mm	■"	■ mm	↳ mm	kg
6263250	KB 3020	3/8"	10,0	1/4"	6,3	31	0,034

KB 3019
Converter 3/8" to 1/2"
for impact sockets



> With square drive as per DIN 3121 - G 10, ISO 1174

Code	No.	□"	□ mm	■"	■ mm	↳ mm	kg
6263410	KB 3019	3/8"	10,0	1/2"	12,5	33	0,061

KB 3090
Extension 3/8"
for impact sockets



> With square drive as per DIN 3121 - G 10, ISO 1174

Code	No.	■"	■ mm	↳ mm	kg
6261710	KB 3090-3	3/8"	10	75	0,09
6262010	KB 3090-5	3/8"	10	125	0,149
6262280	KB 3090-10	3/8"	10	250	0,298

KB 3070
Retaining ring for
impact sockets 3/8"



Code	No.	Designation	∅	kg
6260820	KB 3070 6-12	Retaining ring d 14 mm for 6-12 mm	14,0	0,002
6260900	KB 3070 13-24	Retaining ring d 15,5 mm for 13-24 mm	15,5	0,002

KB 3075
Safety pin for
impact sockets 3/8"



Code	No.	Designation	∅	↳ mm	kg
6261040	KB 3075 6-12	Safety pin d 2,5 mm for 6-12 mm	2,5	14	0,005
6261120	KB 3075 13-24	Safety pin d 2,5 mm for 13-24 mm	2,5	16	0,002

K 19-028
Impact socket set 1/2"
5 pieces



12,5 1/2"

- > 5 Impact sockets suitable for all common pneumatic and electric screwdrivers
- > With square drive as per DIN 3121 - G 12,5, ISO 1174
- > In plastic case

Code	No.	Contents	Pieces	
1646923	K 19-028	10 13 17 19 24	5	0,749

K 19 LS-004
Impact socket set 1/2"
4 pieces



12,5 1/2"

- > 4 Impact socket sets with protective sleeve, hexagon, long form
- > Machine-operated
- > With square drive as per DIN 3121 - G 12,5, ISO 1174
- > Thin-walled to protect the light alloy rims

Code	No.	Contents	Pieces	
2790831	K 19 LS-004	K 19 LS 17 19 21 22	4	0,98

K 19 (MM)
Impact socket 1/2"
hexagon

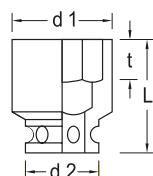

12,5 1/2"

- > Acc. to DIN 3129, ISO 2725-2
- > Machine-operated
- > With square drive as per DIN 3121 - G 12,5, ISO 1174

*** not standardised**

Code	No.		L	d1	d2	t	Recommended accessories	
6160280	K 19 10	10	38,0	17,0	25,0	5,0	KB 1970 10-14, KB 1975 10-14	0,082
6160360	K 19 11	11	38,0	19,0	25,0	5,0	KB 1970 10-14, KB 1975 10-14	0,085
6160440	K 19 12	12	38,0	20,0	25,0	6,0	KB 1970 10-14, KB 1975 10-14	0,084
6160520	K 19 13	13	38,0	21,0	25,0	6,0	KB 1970 10-14, KB 1975 10-14	0,081
6160600	K 19 14	14	38,0	22,0	25,0	7,0	KB 1970 10-14, KB 1975 10-14	0,082
6161680	K 19 15	15	38,0	24,0	30,0	7,0	KB 1970 15-27, KB 1975 15-27	0,125
6160790	K 19 16	16	38,0	25,0	30,0	8,0	KB 1970 15-27, KB 1975 15-27	0,124
6160870	K 19 17	17	38,0	26,0	30,0	9,0	KB 1970 15-27, KB 1975 15-27	0,123
6160950	K 19 18	18	38,0	27,5	30,0	9,0	KB 1970 15-27, KB 1975 15-27	0,122
6161090	K 19 19	19	38,0	27,5	30,0	9,5	KB 1970 15-27, KB 1975 15-27	0,119
6161170	K 19 21	21	38,0	30,0	30,0	11,0	KB 1970 15-27, KB 1975 15-27	0,137
6161250	K 19 22	22	38,0	32,0	30,0	11,0	KB 1970 15-27, KB 1975 15-27	0,142
6161330*	K 19 23	23	38,0	32,0	30,0	13,0	KB 1970 15-27, KB 1975 15-27	0,148
6161410	K 19 24	24	45,0	35,0	30,0	13,0	KB 1970 15-27, KB 1975 15-27	0,154
6182680	K 19 27	27	50,0	38,0	30,0	13,0	KB 1970 15-27, KB 1975 15-27	0,18
1560557*	K 19 30	30	50,0	41,0	30,0	16,0	KB 1970 15-27, KB 1975 15-27	0,256
1783742*	K 19 32	32	50,0	44,0	30,0	17,0	KB 1970 15-27, KB 1975 15-27	0,286

K 19 (AF)
Impact socket 1/2"
hexagon

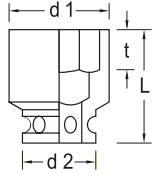

- > Machine-operated
- > With square drive as per DIN 3121 - G 12,5, ISO 1174

Code	No.	AF	L	d1	d2	t	Recommended accessories	kg
6166990	K 19 3/8AF	3/8"	38,0	16,0	25,0	4,0	KB 1970 10-14, KB 1975 10-14	0,079
6162300	K 19 7/16AF	7/16"	38,0	18,0	25,0	6,0	KB 1970 10-14, KB 1975 10-14	0,079
6162650	K 19 1/2AF	1/2"	38,0	20,0	25,0	6,0	KB 1970 10-14, KB 1975 10-14	0,078
6163030	K 19 9/16AF	9/16"	38,0	22,0	25,0	7,0	KB 1970 10-14, KB 1975 10-14	0,08
6163460	K 19 5/8AF	5/8"	38,0	25,0	25,0	8,0	KB 1970 15-27, KB 1975 15-27	0,121
6163700	K 19 11/16AF	11/16"	38,0	25,0	25,0	9,0	KB 1970 15-27, KB 1975 15-27	0,121
6163970	K 19 3/4AF	3/4"	38,0	27,5	30,0	9,5	KB 1970 15-27, KB 1975 15-27	0,115
6168420	K 19 13/16AF	13/16"	38,0	30,0	30,0	11,0	KB 1970 15-27, KB 1975 15-27	0,131
6169820	K 19 7/8AF	7/8"	38,0	32,0	30,0	13,0	KB 1970 15-27, KB 1975 15-27	0,141
6164190	K 19 15/16AF	15/16"	38,0	35,0	30,0	13,0	KB 1970 15-27, KB 1975 15-27	0,156
6169900	K 19 1AF	1"	38,0	35,0	30,0	13,0	KB 1970 15-27, KB 1975 15-27	0,169
6164350	K 19 1.1/16AF	1.1/16"	50,0	38,0	30,0	13,0	KB 1970 15-27, KB 1975 15-27	0,173
6164510	K 19 1.1/8AF	1.1/8"	40,0	38,0	30,0	16,5	KB 1970 15-27, KB 1975 15-27	0,18
6165240	K 19 1.1/4AF	1.1/4"	40,0	44,0	35,0	17,0	KB 1970 15-27, KB 1975 15-27	0,284
6165320	K 19 1.5/16AF	1.5/16"	43,0	45,0	35,0	19,0	KB 1970 15-27, KB 1975 15-27	0,296

K 19 L
Impact socket 1/2"
hexagon, long pattern

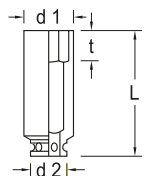

- > Machine-operated
- > With square drive as per DIN 3121 - G 12,5, ISO 1174

Code	No.	mm	L	d1	d2	t	Recommended accessories	kg
6163110	K 19 L 8	8	77,0	15,3	25,0	12,0	KB 1970 10-14, KB 1975 10-14	0,124
6163380	K 19 L 10	10	77,0	17,8	25,0	12,0	KB 1970 10-14, KB 1975 10-14	0,14
6163540	K 19 L 13	13	77,0	21,5	25,0	13,0	KB 1970 10-14, KB 1975 10-14	0,158
6163620	K 19 L 14	14	77,0	22,8	25,0	13,0	KB 1970 10-14, KB 1975 10-14	0,171
6197790	K 19 L 16	16	77,0	24,0	30,0	14,0	KB 1970 15-27, KB 1975 15-27	0,208
6163890	K 19 L 17	17	80,0	26,5	30,0	15,0	KB 1970 15-27, KB 1975 15-27	0,23
6197870	K 19 L 18	18	82,0	27,8	30,0	18,0	KB 1970 15-27, KB 1975 15-27	0,255
6164000	K 19 L 19	19	82,0	29,0	30,0	17,0	KB 1970 15-27, KB 1975 15-27	0,265
6162730	K 19 L 21	21	82,0	31,5	30,0	17,0	KB 1970 15-27, KB 1975 15-27	0,306
6164270	K 19 L 22	22	82,0	32,8	30,0	19,0	KB 1970 15-27, KB 1975 15-27	0,318
6199810	K 19 L 23	23	82,0	34,0	30,0	19,0	KB 1970 15-27, KB 1975 15-27	0,328
6164430	K 19 L 24	24	82,0	35,3	30,0	21,0	KB 1970 15-27, KB 1975 15-27	0,358
6164780	K 19 L 27	27	82,0	39,0	30,0	22,0	KB 1970 15-27, KB 1975 15-27	0,396

K 19 LS

Impact socket 1/2" with protective sleeve hexagon, long pattern

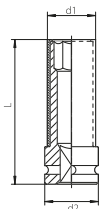

12,5 1/2"

- > Machine-operated
- > With square drive as per DIN 3121 - G 12,5, ISO 1174
- > Thin-walled to protect the light alloy rims

Code	No.	mm	RAL colour tone	RAL	L	d1	d2	t	Recommended accessories	kg
2178214	K 19 LS 17	17	Traffic blue	RAL 5017	81,0	27,0	30,0	15,0	KB 1970 10-14, KB 1975 10-14	0,2
2178222	K 19 LS 19	19	Traffic Green	RAL 6024	82,0	29,0	30,0	17,0	KB 1970 10-14, KB 1975 10-14	0,21
2178230	K 19 LS 21	21	Traffic red	RAL 3020	82,0	30,5	30,0	17,0	KB 1970 10-14, KB 1975 10-14	0,23
2178249	K 19 LS 22	22	Traffic yellow	RAL 1023	82,0	32,3	30,0	19,0	KB 1970 10-14, KB 1975 10-14	0,26

KR 19

Impact socket 1/2" hexagon, for cars

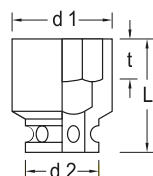

12,5 1/2"

- > Machine-operated
- > With square drive as per DIN 3121 - G 12,5, ISO 1174

Code	No.	mm	L	d1	d2	t	Recommended accessories	kg
6162490	KR 19 17	17	38,0	30,0	30,0	14,0	KB 1970 15-27, KB 1975 15-27	0,174
6162570	KR 19 19	19	38,0	33,0	30,0	18,0	KB 1970 15-27, KB 1975 15-27	0,186

TX K 19

Impact socket 1/2" for protruding TX head screws

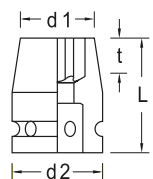

12,5 1/2"

- > Machine-operated
- > Square drive as per DIN 3121 - G 12,5, ISO 1174

Code	No.	mm	M	mm	L	d1	d2	t	Recommended accessories	kg
6223110	TX K 19 E10	E10	M8	9,42	38,0	15,0	25,0	9,0	KB 1970 10-14, KB 1975 10-14	0,084
6223380	TX K 19 E12	E12	M10	11,17	38,0	16,0	25,0	10,0	KB 1970 10-14, KB 1975 10-14	0,085
6223460	TX K 19 E14	E14	M12	12,9	38,0	18,5	25,0	12,0	KB 1970 10-14, KB 1975 10-14	0,086
6223540	TX K 19 E16	E16	M12	14,76	38,0	20,0	25,0	12,0	KB 1970 10-14, KB 1975 10-14	0,088
6223620	TX K 19 E18	E18	M14	16,7	38,0	22,0	25,0	12,0	KB 1970 10-14, KB 1975 10-14	0,087
6223700	TX K 19 E20	E20	M16	18,45	38,0	25,0	30,0	13,0	KB 1970 15-27, KB 1975 15-27	0,14
6223890	TX K 19 E24	E24	M18 - M20	22,16	45,0	28,5	30,0	17,0	KB 1970 15-27, KB 1975 15-27	0,137

IN K 19
Impact socket 1/2"
for in-hex screws

12,5 1/2"

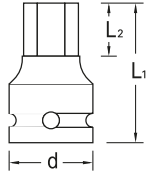

- > Machine-operated
- > Square drive as per DIN 3121 - G 12,5, ISO 1174

Code	No.	mm	L1	L2	d	Recommended accessories	kg
6223970	IN K 19 5	5	44	7,5	25,0	KB 1970 10-14, KB 1975 10-14	0,073
6224000	IN K 19 6	6	44	9,0	25,0	KB 1970 10-14, KB 1975 10-14	0,072
6224190	IN K 19 8	8	44	11,0	25,0	KB 1970 10-14, KB 1975 10-14	0,077
6224270	IN K 19 10	10	44	13,0	25,0	KB 1970 10-14, KB 1975 10-14	0,079
6224350	IN K 19 12	12	50	15,0	30,0	KB 1970 15-27, KB 1975 15-27	0,136
6225320	IN K 19 14	14	50	17,0	30,0	KB 1970 15-27, KB 1975 15-27	0,144
6225670	IN K 19 17	17	50	19,0	30,0	KB 1970 15-27, KB 1975 15-27	0,157

ITX K 19
Impact socket 1/2"
for recessed TX
head screws

12,5 1/2"

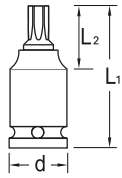

- > Square drive as per DIN 3121 - G 12,5, ISO 1174

Code	No.	M	mm	L1	L2	d	Recommended accessories	kg
6197280	ITX K 19 T30	T30	M6 - M7	5,52	47	26,0	KB 1970 10-14, KB 1975 10-14	0,075
6197360	ITX K 19 T40	T40	M7 - M8	6,65	47	26,0	KB 1970 10-14, KB 1975 10-14	0,077
1603124	ITX K 19 T45	T45	M8 - M10	7,82	47	26,0	KB 1970 10-14, KB 1975 10-14	0,078
6197440	ITX K 19 T50	T50	M10	8,83	47	26,0	KB 1970 10-14, KB 1975 10-14	0,079
6197520	ITX K 19 T55	T55	M12	11,22	26	26,0	KB 1970 10-14, KB 1975 10-14	0,084
6197600	ITX K 19 T60	T60	M14	13,25	47	26,0	KB 1970 10-14, KB 1975 10-14	0,088

KB 1930
Reducer 1/2" to 3/8"
for impact sockets

- > With square drive as per DIN 3121 - G 12,5, ISO 1174, Form F, G and H



Code	No.	"	mm	"	mm	kg
6650370	KB 1930	1/2"	12,0	3/8"	10	0,081

KB 1932
Converter 1/2" to 3/4"
for impact sockets

- > With square drive as per DIN 3121 - G 12,5, ISO 1174, Form F, G and H



Code	No.	"	mm	"	mm	kg
6650020	KB 1932	1/2"	12,5	3/4"	20	0,146

KB 1990
Extension 1/2"
for impact sockets



> With square drive as per
DIN 3121 - G 12,5, ISO
1174, Form F, G and H

Code	No.	"	mm	↳ mm	kg
6655250	KB 1990-5	1/2"	12,5	125	0,256
6650100	KB 1990-10	1/2"	12,5	250	0,461

KB 1995
Universal joint 1/2"
for impact sockets



> With square drive as
per DIN 3121 - G 12,5,
ISO 1174, Form F, G
and H

Code	No.	"	mm	"	mm	↳ mm	kg
6655410	KB 1995	1/2"	12,5	1/2"	12,5	62	0,202

KB 1970
Retaining ring for
impact sockets 1/2"



Code	No.	Designation	∅	kg
6654790	KB 1970-10-14	Retaining ring d 19 mm for 10-14 mm	19,0	0,002
6654870	KB 1970-15-27	Retaining ring d 24 mm for 15-32 mm	24,0	0,002

KB 1975
Safety pin for
impact sockets 1/2"



Code	No.	Designation	∅	↳ mm	kg
6654950	KB 1975 10-14	Safety pin d 3 mm for 10-14 mm	3,0	20	0,002
6655090	KB 1975 15-27	Safety pin d 3 mm for 15-32 mm	3,0	25	0,002

K 32 S
Impact socket 3/4"
with Impact-Fix lock
hexagon UD profile

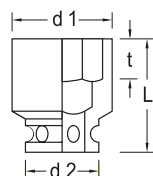

20 **3/4"** **UNIT DRIVE**

> Acc. to DIN 3129,
ISO 2725-2
> Machine-operated
> Square drive as per
DIN 3121 - H 20,
ISO 1174
> Particularly ideal for
work in sensitive areas,
where safety against
loss, process safety and
occupational safety are
required

Code	No.	∅ mm	L	d1	d2	t	kg
2734060	K 32 S 17	17	45,0	31,1	44,0	7,0	0,4
2734079	K 32 S 18	18	45,0	32,4	44,0	8,4	0,42
2734095	K 32 S 19	19	45,0	33,6	44,0	8,4	0,4
2734176	K 32 S 22	22	46,0	37,4	44,0	9,8	0,4
2734184	K 32 S 24	24	46,0	38,9	44,0	11,2	0,34
2734206	K 32 S 27	27	48,0	43,6	44,0	12,6	0,4
2734214	K 32 S 30	30	52,0	47,4	44,0	14,0	0,4
2734230	K 32 S 32	32	52,0	49,9	44,0	15,4	0,4
2734257	K 32 S 33	33	54,0	51,0	44,0	15,4	0,4
2734265	K 32 S 34	34	54,0	52,4	44,0	15,4	0,4
2734273	K 32 S 36	36	56,0	54,9	44,0	16,8	0,5
2734281	K 32 S 38	38	59,0	57,0	44,0	16,8	0,5
2734303	K 32 S 41	41	59,0	61,1	44,0	18,9	0,56

K 32 SL
Impact socket 3/4"
with Impact-Fix lock
hexagon UD profile,
long pattern

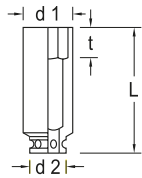

- > Machine-operated
- > Square drive as per DIN 3121 - H 20, ISO 1174
- > Particularly ideal for work in sensitive areas, where safety against loss, process safety and occupational safety are required

Code	No.	Ø mm	L	d1	d2	t	kg
2734311	K 32 SL 17	17	90,0	31,1	44,0	7,0	0,56
2734338	K 32 SL 19	19	90,0	32,4	44,0	8,4	0,6
2734346	K 32 SL 21	21	90,0	36,1	44,0	9,8	0,6
2734354	K 32 SL 22	22	90,0	37,4	44,0	9,8	0,62
2734362	K 32 SL 24	24	90,0	39,9	44,0	11,2	0,62
2734370	K 32 SL 27	27	90,0	43,5	44,0	12,6	0,6
2734389	K 32 SL 30	30	90,0	47,4	44,0	14,0	0,6
2734397	K 32 SL 32	32	90,0	49,9	44,0	15,4	0,7
2734400	K 32 SL 33	33	90,0	51,0	44,0	15,4	0,8
2734419	K 32 SL 34	34	90,0	52,4	44,0	15,4	0,8
2734427	K 32 SL 36	36	90,0	54,9	44,0	16,8	0,8
2734435	K 32 SL 41	41	90,0	61,1	44,0	18,9	0,98

K 32 (MM)
Impact socket 3/4" hex
hexagon

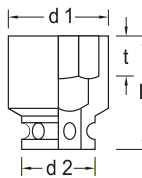

- > Acc. to DIN 3129, ISO 2725-2
- > Machine-operated
- > Square drive as per DIN 3121 - H 20, ISO 1174
- * not standardised**

Code	No.	Ø mm	L	d1	d2	t	Recommended accessories	kg
6282040	K 32 17	17	50,0	29,0	44,0	9,0	KB 3270, KB 3275	0,3
6289990	K 32 18	18	50,0	32,0	44,0	9,0	KB 3270, KB 3275	0,3
6282120	K 32 19	19	50,0	32,0	44,0	9,5	KB 3270, KB 3275	0,293
6282200	K 32 22	22	50,0	38,0	44,0	11,0	KB 3270, KB 3275	0,345
6282390	K 32 24	24	50,0	40,0	44,0	13,0	KB 3270, KB 3275	0,339
6282470	K 32 27	27	54,0	41,0	44,0	13,0	KB 3270, KB 3275	0,339
6282550	K 32 30	30	54,0	44,0	44,0	16,5	KB 3270, KB 3275	0,352
6282630	K 32 32	32	56,0	49,0	44,0	17,0	KB 3270, KB 3275	0,407
6283010*	K 32 33	33	56,0	49,0	44,0	17,0	KB 3270, KB 3275	0,43
6281580	K 32 34	34	56,0	52,0	44,0	19,0	KB 3270, KB 3275	0,475
6282710	K 32 36	36	56,0	52,0	44,0	19,0	KB 3270, KB 3275	0,53
6281740*	K 32 38	38	58,0	54,0	44,0	22,0	KB 3270, KB 3275	0,481
6282980	K 32 41	41	58,0	57,0	44,0	22,0	KB 3270, KB 3275	0,5

K 32 (AF)
Impact socket 3/4"
hexagon

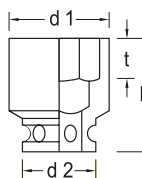

- > Machine-operated
- > Square drive as per DIN 3121 - H 20, ISO 1174

Code	No.	Ø "AF"	L	d1	d2	t	Recommended accessories	kg
6285300	K 32 13/16AF	13/16"	46,0	35,0	44,0	11,0	KB 3270, KB 3275	0,349
6284410	K 32 7/8AF	7/8"	46,0	38,0	44,0	13,0	KB 3270, KB 3275	0,354
6284680	K 32 15/16AF	15/16"	46,0	40,0	44,0	13,0	KB 3270, KB 3275	0,342
6285490	K 32 1AF	1"	46,0	41,0	44,0	13,0	KB 3270, KB 3275	0,34
6285650	K 32 1.1/16AF	1.1/16"	48,0	41,0	44,0	13,0	KB 3270, KB 3275	0,347
6284760	K 32 1.1/8AF	1.1/8"	52,0	44,0	44,0	16,5	KB 3270, KB 3275	0,367
6284840	K 32 1.1/4AF	1.1/4"	52,0	49,0	44,0	17,0	KB 3270, KB 3275	0,418
6284920	K 32 1.5/16AF	1.5/16"	55,0	49,0	44,0	19,0	KB 3270, KB 3275	0,417
6285730	K 32 1.3/8AF	1.3/8"	55,0	52,0	44,0	19,0	KB 3270, KB 3275	0,452
6285060	K 32 1.7/16AF	1.7/16"	56,0	52,0	44,0	19,0	KB 3270, KB 3275	0,439
6285140	K 32 1.1/2AF	1.1/2"	59,0	54,0	44,0	22,0	KB 3270, KB 3275	0,48
6285810	K 32 1.5/8AF	1.5/8"	59,0	57,0	44,0	22,0	KB 3270, KB 3275	0,497
6286030	K 32 1.11/16AF	1.11/16"	64,0	63,0	44,0	25,0	KB 3270, KB 3275	0,674
6286110	K 32 1.3/4AF	1.3/4"	64,0	63,0	44,0	25,5	KB 3270, KB 3275	0,639
6286380	K 32 1.7/8AF	1.7/8"	67,0	67,0	54,0	27,0	KB 3270, KB 3275	0,873
6286460	K 32 2AF	2"	67,0	73,0	54,0	27,0	KB 3270, KB 3275	0,995

K 32 L
Impact socket 3/4"
hexagon, long pattern



- > Machine-operated
- > Square drive as per DIN 3121 - H 20, ISO 1174

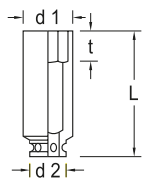

Code	No.	mm	L	d1	d2	t	Recommended accessories	kg
6283600	K 32 L 17	17	90,0	29,0	44,0	9,0	KB 3270, KB 3275	0,727
6283790	K 32 L 19	19	95,0	32,0	44,0	9,5	KB 3270, KB 3275	0,72
6286700	K 32 L 21	21	95,0	35,0	44,0	11,0	KB 3270, KB 3275	0,757
6283870	K 32 L 22	22	95,0	38,0	44,0	11,0	KB 3270, KB 3275	0,739
6283950	K 32 L 24	24	95,0	40,0	44,0	13,0	KB 3270, KB 3275	0,706
6284090	K 32 L 27	27	95,0	41,0	44,0	13,0	KB 3270, KB 3275	0,655
6284170	K 32 L 30	30	95,0	44,0	44,0	16,5	KB 3270, KB 3275	0,644
6284250	K 32 L 32	32	95,0	49,0	44,0	17,0	KB 3270, KB 3275	0,728
6286540	K 32 L 33	33	95,0	49,0	44,0	17,0	KB 3270, KB 3275	0,709
6281660	K 32 L 34	34	95,0	52,0	44,0	19,0	KB 3270, KB 3275	0,858
6284330	K 32 L 36	36	95,0	52,0	44,0	19,0	KB 3270, KB 3275	0,826
6286890	K 32 L 41	41	95,0	57,0	44,0	22,0	KB 3270, KB 3275	0,811

IN K 32
Impact socket 3/4"
for in-hex screws



- > Machine-operated
- > Square drive as per DIN 3121 - H 20, ISO 1174

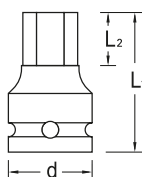

Code	No.	mm	L1	L2	d	Recommended accessories	kg
1956477	IN K 32 14	14	65	17,0	38,0	KB 3270, KB 3275	0,44
1956485	IN K 32 17	17	65	19,0	38,0	KB 3270, KB 3275	0,495
1956493	IN K 32 19	19	65	21,0	44,0	KB 3270, KB 3275	0,53
1956507	IN K 32 22	22	65	24,0	44,0	KB 3270, KB 3275	0,59
1956515	IN K 32 24	24	65	26,0	44,0	KB 3270, KB 3275	0,63
1956523	IN K 32 27	27	65	28,0	44,0	KB 3270, KB 3275	0,695

KB 3219
Reducer 3/4" to 1/2"
for impact sockets

- > With square drive as per DIN 3121, ISO 1174, Form F and H



Code	No.	"	mm	"	mm	mm	kg
6675280	KB 3219	3/4"	20,0	1/2"	12,5	65	0,351

KB 3221
Converter 3/4" to 1"
for impact sockets

- > With square drive as per DIN 3121, ISO 1174, Form F and H



Code	No.	"	mm	"	mm	mm	kg
6671530	KB 3221	3/4"	20,0	1"	25	65	0,445

KB 3290
Extension 3/4"
for impact sockets



- > With square drive as per DIN 3121, ISO 1174, Form F and H

Code	No.	"	mm	↳ mm	kg
6675600	KB 3290-8	3/4"	20	205	0,957
6675790	KB 3290-12	3/4"	20	300	1,328
6675870	KB 3290-16	3/4"	20	400	1,759

KB 3295
Universal joint 3/4"
for impact sockets



- > With square drive as per DIN 3121, ISO 1174, Form F and H

Code	No.	"	mm	"	mm	↳ mm	kg
6676090	KB 3295	3/4"	20,0	3/4"	20	94	0,623

KB 3270
Retaining ring for
impact sockets 3/4"



Code	No.	Designation	∅	kg
6675360	KB 3270	Retaining ring d 36 mm	36,0	0,004

KB 3275
Safety pin for
impact sockets 3/4"



Code	No.	Designation	∅	↳ mm	kg
6675440	KB 3275	Safety pin d 4 mm	4,0	35	0,004

K 21 S
Impact socket 1"
with Impact-Fix lock
hexagon UD profile

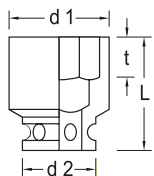

- 25** **1"** **UNIT DRIVE**
- > Acc. to DIN 3129, ISO 2725-2
 - > Machine-operated
 - > Square drive as per DIN 3121 - H 25, ISO 1174
 - > Particularly ideal for work in sensitive areas, where safety against loss, process safety and occupational safety are required

Code	No.	mm	L	d1	d2	t	kg
2734443	K 21 S 22	22	55,0	40,4	54,0	9,8	0,6
2734451	K 21 S 24	24	55,0	42,9	54,0	11,2	0,6
2734478	K 21 S 27	27	55,0	46,7	54,0	12,6	0,6
2734486	K 21 S 30	30	57,0	50,4	54,0	14,0	0,6
2734494	K 21 S 32	32	57,0	52,9	54,0	15,4	0,6
2734508	K 21 S 33	33	57,0	54,0	54,0	15,4	0,6
2734516	K 21 S 34	34	57,0	55,4	54,0	15,4	0,6
2734524	K 21 S 36	36	60,0	57,9	54,0	16,8	0,68
2734540	K 21 S 38	38	64,0	60,4	54,0	16,8	0,7
2734559	K 21 S 41	41	64,0	64,2	54,0	18,9	0,7
2734567	K 21 S 42	42	64,0	65,4	54,0	18,6	0,7
2734575	K 21 S 46	46	69,0	70,4	54,0	21,0	0,7
2734583	K 21 S 50	50	72,0	75,4	54,0	23,1	0,8
2734591	K 21 S 55	55	76,0	81,7	54,0	25,2	0,8
2734605	K 21 S 60	60	82,0	87,9	54,0	27,3	0,8
2734613	K 21 S 65	65	85,0	94,2	54,0	29,4	0,9
2734621	K 21 S 70	70	88,0	100,4	54,0	31,5	0,9
2734648	K 21 S 75	75	92,0	106,0	54,0	33,6	0,9
2734656	K 21 S 80	80	97,0	113,0	54,0	36,4	1

i IMPACT-FIX LOCK

YOUR ADVANTAGES?

- Integrated, secure two-pin lock including ring.
- An extra feature from GEDORE - for increased safety in the workplace.
- Particularly suitable for working in sensitive areas permanently governed by certainty against loss, process reliability and occupational safety.
- Examples: overhead power line construction, wind power plants, machine engineering or the automotive sector.



- Very safe and extremely practice-oriented, and very easy to handle.
- Double ring groove for easily sliding the ring.
- Minimisation of the risk of injury compared to standard systems available on the market. The securing ring is not catapulted out of the rotating insert if the securing pin tears.
- Wherever major forces prevail, correct and appropriate securing and handling of tools is a key element of good screwed connections.
- Standard practice: the bothersome and awkward fitting of the loose securing pin and ring is often simply neglected or forgotten, or the pin and ring are no longer to be found.
- Thanks to the Impact-Fix lock integrated in the socket, 3 elements no longer need to be installed (insert, pin and ring). The securing pins and rings are always secured to the socket (3 in 1). The pins are automatically pressed into the drill holes in the square drive when the ring is secured in place.
- DBGM (German utility-patent)

EASY TO USE ...

Double ring groove for easily sliding the ring thanks to integrated two-pin lock including ring.

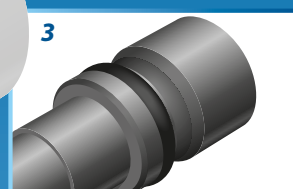
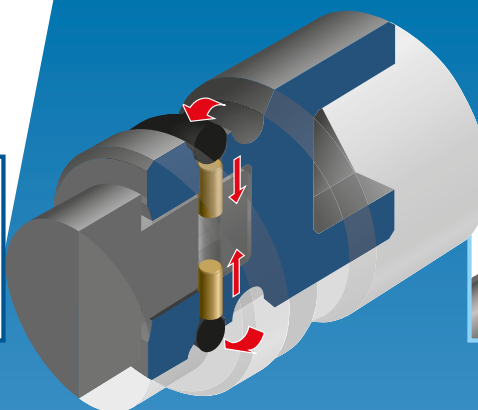
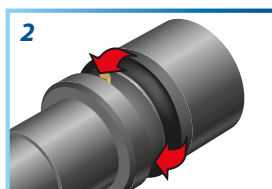
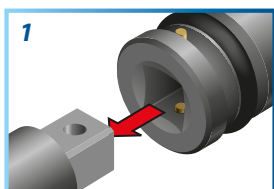

MACHINE- OR HAND-OPERATED ...

... electric, hydraulic, pneumatic or with torque multiplier by hand.

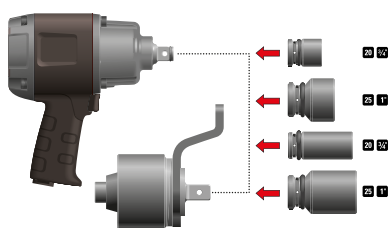

THE ADVANTAGE IS OBVIOUS:

thanks to the Impact-Fix lock integrated in the socket, three elements no longer need to be installed (insert, pin and ring).



K 21 SL

Impact socket 1" with Impact-Fix lock hexagon UD profile, long pattern

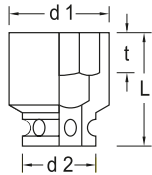

- > Machine-operated
- > Square drive as per DIN 3121 - H 25, ISO 1174
- > Particularly ideal for work in sensitive areas, where safety against loss, process safety and occupational safety are required

Code	No.	Ø mm	L	d1	d2	t		kg
2734664	K 21 SL 22	22	100,0	40,4	54,0	9,8		0,6
2734672	K 21 SL 24	24	100,0	42,9	54,0	11,2		0,6
2734680	K 21 SL 27	27	100,0	46,7	54,0	12,6		0,6
2734699	K 21 SL 30	30	100,0	50,4	54,0	14,0		0,8
2734702	K 21 SL 32	32	100,0	52,9	54,0	15,4		0,8
2734710	K 21 SL 33	33	100,0	54,0	54,0	15,4		0,8
2734729	K 21 SL 34	34	100,0	55,4	54,0	15,4		1
2734737	K 21 SL 36	36	100,0	57,9	54,0	16,8		1
2734745	K 21 SL 38	38	100,0	60,4	54,0	16,8		1,14
2734753	K 21 SL 41	41	100,0	64,2	54,0	18,9		1,28
2734761	K 21 SL 46	46	100,0	70,4	54,0	18,9		1,42

K 21 (MM)

Impact socket 1" hexagon

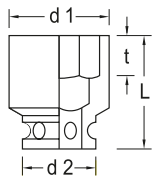

- > Acc. to DIN 3129, ISO 2725-2
- > Machine-operated
- > Square drive as per DIN 3121 - H 25, ISO 1174
- * not standardised**

Code	No.	Ø mm	L	d1	d2	t	Recommended accessories	kg
6183060	K 21 22	22	60,0	40,0	54,0	11,0	KB 2170, KB 2175	0,561
6183140	K 21 24	24	60,0	42,0	54,0	13,0	KB 2170, KB 2175	0,611
6183220	K 21 27	27	60,0	46,0	54,0	13,0	KB 2170, KB 2175	0,614
6183300	K 21 30	30	58,0	50,0	54,0	16,5	KB 2170, KB 2175	0,619
6183490	K 21 32	32	62,0	51,0	54,0	17,0	KB 2170, KB 2175	0,608
6183650*	K 21 33	33	60,0	54,0	54,0	17,0	KB 2170, KB 2175	0,615
6196980	K 21 34	34	62,0	54,0	54,0	19,0	KB 2170, KB 2175	0,624
6183570	K 21 36	36	67,0	54,0	54,0	19,0	KB 2170, KB 2175	0,598
6184890*	K 21 38	38	67,0	60,0	54,0	19,0	KB 2170, KB 2175	0,764
6183730	K 21 41	41	67,0	63,0	54,0	22,0	KB 2170, KB 2175	0,794
6184970*	K 21 42	42	74,0	63,0	54,0	22,0	KB 2170, KB 2175	0,781
6183810	K 21 46	46	74,0	70,0	54,0	25,5	KB 2170, KB 2175	0,974
6184030	K 21 50	50	80,0	73,0	54,0	27,0	KB 2170, KB 2175	1,018
6184110	K 21 55	55	84,0	82,0	54,0	33,0	KB 2170, KB 2175	1,298
6184380	K 21 60	60	87,0	86,0	54,0	33,0	KB 2170, KB 2175	1,481
6184460	K 21 65	65	90,0	92,0	54,0	35,0	KB 2170, KB 2175	1,682
6184540	K 21 70	70	96,0	96,0	54,0	38,0	KB 2170, KB 2175	1,812
6184620*	K 21 75	75	98,0	100,0	86,0	41,0	KB 3770, KB 3775	2,69
6184700*	K 21 80	80	100,0	105,0	86,0	44,0	KB 3770, KB 3775	2,936

K 21 (AF)
Impact socket 1"
hexagon

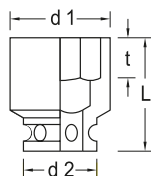

25 1"

- > Machine-operated
- > Square drive as per DIN 3121 - H 25, ISO 1174

Code	No.	AF	L	d1	d2	t	Recommended accessories	kg
6186320	K 21 1AF	1"	56,0	43,0	54,0	13,0	KB 2170, KB 2175	0,611
6186400	K 21 1.1/4AF	1.1/4"	57,0	51,0	54,0	17,0	KB 2170, KB 2175	0,614
6186590	K 21 1.7/16AF	1.7/16"	60,0	54,0	54,0	19,0	KB 2170, KB 2175	0,593
6186750	K 21 1.1/2AF	1.1/2"	64,0	60,0	54,0	22,0	KB 2170, KB 2175	0,776
6186670	K 21 1.5/8AF	1.5/8"	64,0	63,0	54,0	22,0	KB 2170, KB 2175	0,796
6186830	K 21 1.13/16AF	1.3/16"	69,0	70,0	54,0	25,5	KB 2170, KB 2175	0,972
6186910	K 21 1.7/8AF	1.7/8"	72,0	70,0	54,0	27,0	KB 2170, KB 2175	0,981
6187050	K 21 2.1/4AF	2.1/4"	80,0	82,0	54,0	33,0	KB 2170, KB 2175	1,365

K 21 L
Impact socket 1"
hexagon, long pattern

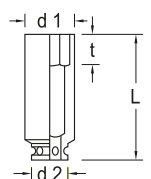

25 1"

- > Machine-operated
- > Square drive as per DIN 3121 - H 25, ISO 1174

Code	No.	mm	L	d1	d2	t	Recommended accessories	kg
6185350	K 21 L 22	22	100,0	40,0	54,0	11,0	KB 2170, KB 2175	1,103
6185430	K 21 L 24	24	100,0	42,0	54,0	13,0	KB 2170, KB 2175	1,234
6185510	K 21 L 27	27	100,0	46,0	54,0	13,0	KB 2170, KB 2175	1,227
6185780	K 21 L 30	30	100,0	50,0	54,0	16,5	KB 2170, KB 2175	1,141
6185860	K 21 L 32	32	100,0	51,0	54,0	17,0	KB 2170, KB 2175	1,101
6197950	K 21L 33	33	100,0	54,0	54,0	17,0	KB 2170, KB 2175	1,104
6197010	K 21L 34	34	100,0	54,0	54,0	19,0	KB 2170, KB 2175	1,189
6185940	K 21 L 36	36	100,0	54,0	54,0	19,0	KB 2170, KB 2175	1,022
6186080	K 21 L 38	38	100,0	60,0	54,0	22,0	KB 2170, KB 2175	1,262
6186160	K 21 L 41	41	100,0	63,0	54,0	22,0	KB 2170, KB 2175	1,42
6186240	K 21 L 46	46	100,0	70,0	54,0	25,5	KB 2170, KB 2175	1,619

IN K 21
Impact socket 1"
for in-hex screws

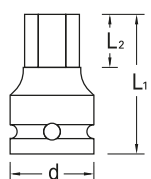

- > Machine-operated
- > Square drive as per DIN 3121 - H 25, ISO 1174

Code	No.	mm	L1	L2	d	Recommended accessories	kg
1956558	IN K 21 19	19	75	21,0	54,0	KB 2170, KB 2175	0,65
1956566	IN K 21 22	22	75	24,0	54,0	KB 2170, KB 2175	0,675
1956574	IN K 21 24	24	75	26,0	54,0	KB 2170, KB 2175	0,7
1956582	IN K 21 27	27	75	28,0	54,0	KB 2170, KB 2175	0,73
1577514	IN K 21 30	30	75	29,0	54,0	KB 2170, KB 2175	0,735
1956590	IN K 21 32	32	75	30,0	54,0	KB 2170, KB 2175	0,8
1956604	IN K 21 36	36	75	30,0	54,0	KB 2170, KB 2175	0,86

KB 2132
Reducer 1" to 3/4"
for impact sockets



> With square drive as per DIN 3121, ISO 1174, Form F and H

Code	No.	□"	□ mm	■"	■ mm	↳ mm	⚖
6657460	KB 2132	1"	25,0	3/4"	20	75	0,661

KB 2137
Convector 1" to 1.1/2"
for impact sockets



> With square drive as per DIN 3121, ISO 1174, Form F and H

Code	No.	□"	□ mm	■"	■ mm	↳ mm	⚖
6657890	KB 2137	1"	25,0	1.1/2"	40	82	0,988

KB 2190
Extension 1"
for impact sockets



> With square drive as per DIN 3121, ISO 1174, Form F and H

Code	No.	■"	■ mm	↳ mm	⚖
6657970	KB 2190-8	1"	25	208	1,477
6658000	KB 2190-12	1"	25	300	2,01
6658190	KB 2190-16	1"	25	405	2,587

KB 2195
Universal joint 1"
for impact sockets



> With square drive as per DIN 3121, ISO 1174, Form F and H

Code	No.	□"	□ mm	■"	■ mm	↳ mm	⚖
6658350	KB 2195	1"	25,0	1"	25	140	1,425

KB 2170
Retaining ring for impact sockets 1"



Code	No.	Designation	∅	⚖
6657620	KB 2170	Retaining ring d 45 mm	45,0	0,008

KB 2175
Safety pin for impact sockets 1"



Code	No.	Designation	∅	↳ mm	⚖
6657700	KB 2175	Safety pin d 5 mm	5,0	45	0,007

K 37
Impact socket 1.1/2" hexagon

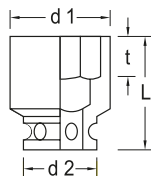

- > Acc. to DIN 3129, ISO 2725-2
- > Machine-operated
- > Square drive as per DIN 3121 - H 40, ISO 1174

* not standardised

Code	No.	mm	L	d1	d2	t	Recommended accessories	kg
6328130	K 37 46	46	84,0	76,0	86,0	25,5	KB 3770, KB 3775	2,265
6328210*	K 37 50	50	87,0	81,0	86,0	27,0	KB 3770, KB 3775	2,306
6328480	K 37 55	55	90,0	86,0	86,0	30,0	KB 3770, KB 3775	2,459
6328560	K 37 60	60	92,0	93,0	86,0	33,0	KB 3770, KB 3775	2,744
6328640	K 37 65	65	95,0	97,0	86,0	35,0	KB 3770, KB 3775	3,215
6328720	K 37 70	70	100,0	105,0	86,0	38,0	KB 3770, KB 3775	3,535
6328800	K 37 75	75	103,0	110,0	86,0	41,0	KB 3770, KB 3775	3,735
6328990	K 37 80	80	110,0	116,0	86,0	44,0	KB 3770, KB 3775	4,185
6329020	K 37 85	85	118,0	125,0	86,0	47,0	KB 3770, KB 3775	4,795
6329100	K 37 90	90	118,0	130,0	86,0	49,0	KB 3770, KB 3775	5,46
6329290*	K 37 95	95	118,0	137,0	95,0	49,0	KB 6470, KB 6475	9
6329370*	K 37 100	100	125,0	140,0	127,0	54,0	KB 6470, KB 6475	8,095
6329450*	K 37 105	105	125,0	150,0	127,0	54,0	KB 6470, KB 6475	7,24
6329530*	K 37 110	110	137,0	156,0	127,0	62,0	KB 6470, KB 6475	9,38
6329610*	K 37 115	115	137,0	160,0	127,0	67,0	KB 6470, KB 6475	10,575
6329880*	K 37 120	120	145,0	168,0	127,0	67,0	KB 6470, KB 6475	11,77

K 37 L
Impact socket 1.1/2" hexagon, long pattern

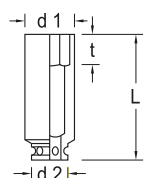

- > Machine-operated
- > Square drive as per DIN 3121 - H 40, ISO 1174

Code	No.	mm	L	d1	d2	t	Recommended accessories	kg
6330110	K 37 L 41	41	140,0	70,0	86,0	22,0	KB 3770, KB 3775	4,4
6330380	K 37 L 46	46	140,0	75,0	86,0	25,5	KB 3770, KB 3775	4,33
6330460	K 37 L 50	50	140,0	80,0	86,0	27,0	KB 3770, KB 3775	4,365
6330540	K 37 L 55	55	140,0	86,0	86,0	30,0	KB 3770, KB 3775	3,95
6330620	K 37 L 60	60	140,0	92,0	86,0	33,0	KB 3770, KB 3775	4,135
6330700	K 37 L 65	65	140,0	100,0	86,0	35,0	KB 3770, KB 3775	4,62
6330890	K 37 L 70	70	140,0	105,0	86,0	38,0	KB 3770, KB 3775	4,805
6330970	K 37 L 75	75	140,0	109,0	86,0	41,0	KB 3770, KB 3775	5,395
6331000	K 37 L 80	80	140,0	115,0	86,0	44,0	KB 3770, KB 3775	8,22
6331190	K 37 L 85	85	140,0	121,0	86,0	47,0	KB 3770, KB 3775	6,154
6331270	K 37 L 90	90	140,0	130,0	86,0	49,0	KB 3770, KB 3775	6,595
6331350	K 37 L 95	95	150,0	137,0	127,0	49,0	KB 6470, KB 6475	9,96
6331430	K 37 L 100	100	150,0	144,0	127,0	54,0	KB 6470, KB 6475	9,964
6331510	K 37 L 105	105	150,0	154,0	127,0	54,0	KB 6470, KB 6475	12,5
6331780	K 37 L 110	110	160,0	157,0	127,0	62,0	KB 6470, KB 6475	12,8
6331860	K 37 L 115	115	160,0	164,0	127,0	67,0	KB 6470, KB 6475	12,225
6331940	K 37 L 120	120	170,0	167,0	127,0	67,0	KB 6470, KB 6475	13,845

KB 3721
Reducer 1.1/2" to 1" for impact sockets



- > With square drive as per DIN 3121, ISO 1174, Form F and H

Code	No.	"	mm	"	mm	mm	kg
6676410	KB 3721	1.1/2"	40,0	1"	25	95	1,992

KB 3764
 Converter 1.1/2"
 to 2.1/2"
 for impact sockets

> With square drive as
 per DIN 3121, ISO 1174,
 Form F and H



Code	No.	□"	□mm	■"	■mm	↳mm↳	
1531220	KB 3764	1.1/2"	40,0	2.1/2	63	93	3,6

KB 3770
 Retaining ring for
 impact sockets 1.1/2"



Code	No.	Designation	∅	
6676760	KB 3770	Retaining ring d 75 mm	75,0	0,026

KB 3775
 Safety pin for
 impact sockets 1.1/2"



Code	No.	Designation	∅	↳mm↳	
6676840	KB 3775	Safety pin d 6 mm	6,0	75	0,017

K 64
 Impact socket 2.1/2"
 hexagon

> Acc. to DIN 3129,
 ISO 2725-2
 > Machine-operated
 > Square drive as per
 DIN 3121 - H 63,
 ISO 1174

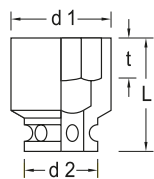

Code	No.	∅mm	L	d1	d2	t	Recommended accessories	
6371300	K 64 75	75	125,0	115,0	127,0	41,0	KB 6470, KB 6475	7,35
6371490	K 64 80	80	125,0	115,0	127,0	44,0	KB 6470, KB 6475	7,015
6371570	K 64 85	85	130,0	127,0	127,0	47,0	KB 6470, KB 6475	7,295
6371650	K 64 90	90	132,0	135,0	127,0	49,0	KB 6470, KB 6475	7,955
6371730	K 64 95	95	95,0	140,0	127,0	49,0	KB 6470, KB 6475	8,12
6371810	K 64 100	100	141,0	145,0	127,0	54,0	KB 6470, KB 6475	8,905
6372030	K 64 105	105	141,0	150,0	127,0	54,0	KB 6470, KB 6475	9,145
6372110	K 64 110	110	150,0	160,0	127,0	62,0	KB 6470, KB 6475	11
6372380	K 64 115	115	150,0	165,0	127,0	62,0	KB 6470, KB 6475	11,13
6372460	K 64 120	120	158,0	170,0	127,0	67,0	KB 6470, KB 6475	12,03

KB 6437
 Reducer 2.1/2" to 1.1/2"
 for impact sockets

> With square drive as
 per DIN 3121, ISO 1174,
 Form F and H



Code	No.	□"	□mm	■"	■mm	↳mm↳	
6699700	KB 6437	2.1/2	63,0	1.1/2"	40	138	7,09

KB 6470
Retaining ring for
impact sockets 2.1/2"



Code	No.	Designation	∅	
6699890	KB 6470	Retaining ring d 114 mm	114,0	0,04

KB 6475
Safety pin for
impact sockets 2.1/2"



Code	No.	Designation	∅	↳ mm ↲	
6699970	KB 6475	Safety pin d 8 mm	8,0	110	0,043

K 1900
Hand-operated
impact driver 1/2"

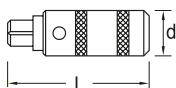

- > Particularly suitable for loosening stuck screws by hammer
- > Reversible for right and left hand operation
- > 1/2" square drive for Impact sockets

Code	No.	■ mm	■ "	L	d	
6654440	K 1900	12,5	1/2"	123	34,0	0,579

K 1900-018
Screw remover set
18 pieces



12,5 **1/2"** **8** **5/16"**

- > Complete with the most frequently used bits, for use on screws and bolts with slotted, cross-head or hexagon heads
- > Hammer-operated screw loosener for loosening stuck screws, adjustable for right and left-hand operation
- > In plastic case

Code	No.	Contents	Pieces	
6654600	K 1900-018	880 5,5 6,5 8 12 885 4 5 6 8 10 890 2 3 4 887 TX T27 T30 T40 T45 KB 819 K 1900	18	1,249

WWW.GEDORE.COM

2169-012

Magazine handle screwdriver
with ratchet function
SilentGEAR 1/4"



- > Loaded magazine screwdriver with ratchet function
- > For precision working in confined spaces
- > Very small return angle, practically 0° (not measurable with mechanical measuring equipment)

- > Very compact 2K handle with bit garage
- > Rotating ring for clockwise/anticlockwise rotation adjustment, screw tightening also without ratchet function due to neutral central position with ratchet lock



Code	No.	1/4"	6.3	Contents			
3031691	2169-012	1/4"	6.3	SL 0,8x4,5 1,0x5,5 1,2x6,5 PH 1 2 3 PZ 1 2 TX T10 T15 T20 T25	125	250	0,235

2675

Ratchet screwdriver
SilentGEAR 1/4"
bit holder



- > Highly compact ratchet screwdriver
- > For precision working in confined spaces
- > Very small return angle, practically 0° (not measurable with mechanical measuring equipment)

- > Rotating ring for clockwise/anticlockwise rotation adjustment, screw tightening also without ratchet function due to neutral central position with ratchet lock



Code	No.	1/4"	6,3			
3031918	2675	1/4"	6,3	115	225	0,14

680

Screwdriver bit 1/4",
Value pack
for slotted head screws

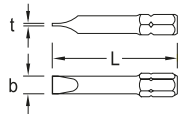

- > For hand operation and use in electric and air tools
- > Acc. to DIN ISO 2351-1
- > With hexagon drive as per DIN 3126 - C 6,3 (1/4")
- > 10 pieces Value packs

Code	No.		t	L	Contents	
6538020	680 7 S-010	7	1,2	25	10x	0,06
6538100	680 8 S-010	8	1,6	25	10x	0,07

685

Screwdriver bit 1/4",
Value pack
for in-hex screws

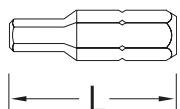

- > For hand operation and use in electric and air tools
- > Acc. to DIN ISO 2351-3
- > With hexagon drive as per DIN 3126 - C 6,3 (1/4")
- > 10 pieces Value packs

Code	No.		ISO 4762	DIN 7984	L	Contents	
6538880	685 2,5 S-010	2,5	M3	M4	25	10x	0,05
6538960	685 3 S-010	3	M4	M5	25	10x	0,05
6539180	685 4 S-010	4	M5	M6	25	10x	0,06
6539260	685 5 S-010	5	M6	M8	25	10x	0,06
6539340	685 6 S-010	6	M8	M10	25	10x	0,07
6539420	685 8 S-010	8	M10	M12	33	10x	0,09

690
Screwdriver bit 1/4",
Value pack
for cross-head screws
PH

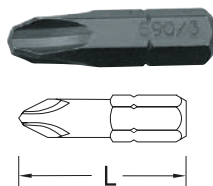

6,3 1/4"

- > For hand operation and use in electric and air tools
- > Acc. to DIN ISO 2351-2, Spitze nach DIN ISO 8764-1 PH
- > With hexagon drive as per DIN 3126 - C 6,3 (1/4")
- > 10 pieces Value packs

Code	No.	⊕ PH	L	Contents	kg
6541320	690 2 S-010	2	25	10x	0,06
6541400	690 2 L S-010	2	50	10x	0,12
6541590	690 3 S-010	3	25	10x	0,06
6541670	690 3 L S-010	3	50	10x	0,12

690 PZD
Screwdriver bit 1/4",
Value pack
for cross-head screws
Pozi PZ

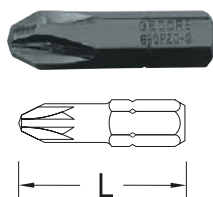

6,3 1/4"

- > For hand operation and use in electric and air tools
- > Acc. to DIN ISO 2351-2, Spitze nach DIN ISO 8764-1 PZ
- > With hexagon drive as per DIN 3126 - C 6,3 (1/4")
- > 10 pieces Value packs

Code	No.	⊕ PZ	L	Contents	kg
6552790	690 PZD 1 S-010	1	25	10x	0,05
1827022	690 PZD 1 L S-010	1	50	10x	0,12
6552870	690 PZD 2 S-010	2	25	10x	0,06
6553090	690 PZD 3 S-010	3	25	10x	0,06
6553170	690 PZD 3 L S-010	3	50	10x	0,12
6553680	690 PZD 4 S-010	4	32	10x	0,15

686
Screwdriver bit 1/4",
Value pack
for multi-spline screws
RIBE®

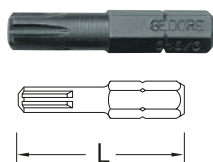

6,3 1/4"

- > For hand operation and use in electric and air tools
- > With hexagon drive as per DIN 3126 - C 6,3 (1/4")
- > 10 pieces Value packs

Code	No.	⊕	L	Contents	kg
6540780	686 5 S-010	M5	33	10x	0,07
6540940	686 8 S-010	M8	33	10x	0,11

685 X
Screwdriver bit 1/4",
Value pack
for multi-point screws
XZN

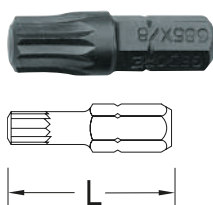

6,3 1/4"

- > For hand operation and use in electric and air tools
- > Acc. to DIN 65254
- > With external hexagon drive to DIN 3126 - C 6.3 (1/4"), tip to DIN 2325
- > 10 pieces Value packs

Code	No.	⊕	L	Contents	kg
6540190	685 X 6 S-010	M6	25	10x	0,06
6540270	685 X 8 S-010	M8	25	10x	0,08

687 TX
Screwdriver bit 1/4",
Value pack
for recessed TX head
screws

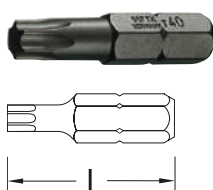

6,3 1/4"

- > For hand operation and use in electric and air tools
- > With hexagon drive as per DIN 3126 - C 6,3 (1/4")
- > 10 pieces Value packs

Code	No.	⊕	mm	L	Contents	kg	
6541910	687 TX T7 S-010	T7	M2,5	1,99	25	10x	0,05
6542210	687 TX T10 S-010	T10	M3 - M3,5	2,74	25	10x	0,05
6542480	687 TX T15 S-010	T15	M3,5 - M4	3,27	25	10x	0,05
6542560	687 TX T20 S-010	T20	M4 - M5	3,86	25	10x	0,05
6542640	687 TX T25 S-010	T25	M4,5 - M5	4,43	25	10x	0,06
6542720	687 TX T27 S-010	T27	M4,5 - M6	4,99	25	10x	0,06
6542800	687 TX T30 S-010	T30	M6 - M7	5,52	25	10x	0,06
6542990	687 TX T40 S-010	T40	M7 - M8	6,65	25	10x	0,07

689 TS
Screwdriver bit 1/4"
TORQ-SET



- > For hand operation and use in electric and air tools
- > Acc. to DIN ISO 3126, ISO 1173
- > With hexagon drive as per DIN 3126 - C 6,3 (1/4")

Code	No.	Tip size TORQ SET	L	Contents	
1965506	689 TS 2	2	82	1x	0,006
1965514	689 TS 4	4	82	1x	0,006
1965522	689 TS 6	6	82	1x	0,006
1965530	689 TS 8	8	82	1x	0,006
1965549	689 TS 10	10	82	1x	0,006

KB 619 - KB 630
Adaptor pieces for
screwdriver bits 1/4"

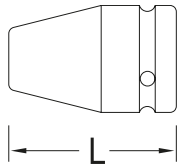

- > Acc. to DIN 7427 Form A
- > Hexagon socket according to DIN 3126 - D 6.3 (1/4")
- > Square drive Form G DIN 3121
- > For hand-operated or power tools
- > When using machines, we recommend the use of a circlip and pin

***not standardised**

Code	No.	Hexagon "	Hexagon mm	Square "	Square mm	Length mm	
6524230	KB 620	1/4"	6,3	1/4"	6,3	25	0,017
6530040*	KB 630	1/4"	6,3	3/8"	10	30	0,04
6524150	KB 619	1/4"	6,3	1/2"	12,5	35	0,072

620-024
Bit set 1/4"
24 pieces



- > In plastic case
- > Dimensions: 110 x 65 x 31 mm

Code	No.	Contents	Pieces	
1815695	620-024	Screwdriver bit 1/4" for slotted screws No. 680 4 6.5 Screwdriver bit 1/4" for hexagon socket screws No. 685 3 4 5 6 Screwdriver bit 1/4" for multi-tooth socket screws XZN No. 685 X 5 6 8 Screwdriver bit 1/4" for cross-head screws PH No. 690 1 2 Screwdriver bit 1/4" for cross-head screws PZ No. 690 PZD 1 2 3 Screwdriver bit 1/4" for recessed TX screws with pin No. 687 TX T8 T9 T10 T15 T20 T25 T27 T30 T40 Bit adapter 1/4" No. 620	24	0,185

666-006
Bit box socket
machine mount
6 pieces



- > Socket wrench inserts with magnet for damage-free insertion and removal of hexagon head screws
- > Especially suitable for self-drilling screws

Code	No.	Contents	Pieces	
2993244	666-006	Socket wrench machine mount 1/4" 7 8 10 12 13 mm and 3/8"	6	0,24

666-032-A
Bit-Box Allround
32 pieces



- > For industry, the tradesmen and DIY
- > 1/4" bit holder with quick-grip system
- > Made in Germany

Code	No.	Contents	Pieces	
2993236	666-032-A	Screwdriver bit 1/4" for slotted screws No. 680 4.5 (1x) 5.5 (2x) 6.5 (1x) Screwdriver bit 1/4" for cross-head screws PH No. 690 1 (2x) 2 (3x) 3 (1x) Screwdriver bit 1/4" for cross-head screws PZ No. 690 PDZ 1 (2x) 2 (4x) 3 (1x) Screwdriver bit 1/4" for inside TX screws No. 687 TX T10 (1x) T15 (1x) T20 (2x) T25 (3x) T30 (2x) T40 (1x) Screwdriver bit 1/4" for multi-tooth socket screws XZN No. 685 X 3 (1x) 4 (1x) 5 (1x) 6 (1x) Bit holder 1/4", magnetic No. 700	32	0,246

666-032-J
Bit-Box Industry
32 pieces

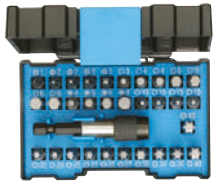

6,3 1/4"

- > Specially adapted for use in modern industrial plants
- > 1/4" bit holder with quick-grip system
- > Made in Germany

Code	No.	Contents	Pieces	kg
2993228	666-032-J	PH 1 (1x) PH 2 (3x) PH 3 (1x) TX T10 (2x) T15 (2x) T20 (2x) T25 (3x) T27 (1x) T30 (3x) T40 (2x) 3 (1x) 4 (2x) 5 (2x) 6 (2x) XZN M4 (1x) M5 (1x) M6 (1x) M8 (1x) Adaptor 1/4"-1/4"	32	0,26

666-042
Torsions bit set
42 pieces



6,3 1/4"

- > Torsionszone to protect bits under load. Peak torques are easily reached, which increases the lifetime of the bit
- > Incl. extremely slim, self-locking magnetic bit holder with quick change function
- > For soft and hard bolting tasks
- > Suitable for use in Impact sockets

Code	No.	Contents	Pieces	kg
3100316	666-042	1/4" bits, 25mm: 1/4" slot 5,5, 6,5 mm 1/4" cross recess PR 2 1/4" cross recess PH 1 2 2 3 1/4" cross recess PZ 1 2 2 3 1/4" TX T10 T15 T20 T25 T30 T40 1/4" bits, 50mm 1/4": hexagon 3 4 5 mm 1/4" cross recess PH 1 2 2 3 1/4" cross recess PZ 1 2 2 3 1/4" TX T10 T15 T20 T25 T30 1/4" bits, 88,9mm: 1/4" slot 5,5 mm 1/4" cross recess PH 2 1/4" cross recess PZ 2 1/4" TX T25 Drive adapter 1/4" hexagonal x 1/4" square, L. 50mm Drive adapter 1/4" hexagonal x 3/8" square, L. 50mm Socket wrench insert, magnetic, with 1/4" hex drive SW 8mm, L.67mm Socket wrench insert, magnetic, with 1/4" hex drive SW 10mm, L.67mm Socket wrench insert, magnetic, with 1/4" hex drive SW 13mm, L.67mm Bit-Holder 1/4" One-touch Slim Lock, L.66,5mm	42	0,67

620 - 630
Bit adaptor 1/4"



- > With hexagon drive as per DIN 3126 - D 6,3 (1/4")
- > with square drive as per DIN 3120 - C 6,3 (1/4") or C 10 (3/8")

Code	No.	Hexagon Drive	Hexagon Drive	Square Drive	Square Drive	Length [mm]	kg
1649329	620	1/4"	6,3	1/4"	6,3	25	0,02
1973312	630	1/4"	6,3	3/8"	10,0	25	0,025

670
Bit screwdriver 1/4"

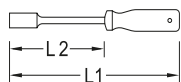

- > With hexagon drive as per DIN 3126 - D 6,3 (1/4") for Bits

- > With strong magnetic holder

Code	No.	Hexagon Drive	Hexagon Drive	Length [mm]	Length [mm]	kg
6536590	670	1/4"	6,3	100	210	0,14

670 K

Bit screwdriver 1/4"
short pattern



- > With hexagon drive as per DIN 3126 - D 6,3 (1/4") for Bits
- > With hexagon drive as per DIN 3126 - D 6,3 (1/4")

- > with square drive as per DIN 3120 - C 6,3 (1/4") or C 10 (3/8")
- > With strong magnetic holder

Code	No.	Hexagon	Hexagon	mm	kg
1953796	670 K	1/4"	6,3	80	0,1

671

Bit ratchet 1/4"

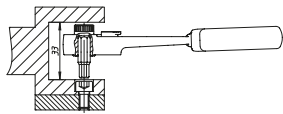

- > With knurled head for quick starting or counter-holding of screws
- > Hexagon socket according to DIN 3126 - D 6.3 (1/4")

- > Slim line design for working in confined spaces

Code	No.	Hexagon	Hexagon	Angle	mm	mm	kg
6535350	671	1/4"	6,3	15°	127	18,3	0,108

673

Adaptor



- > Acc. to DIN 7428, ISO 3317
- > External hexagon according to DIN 3126 - E 6.3 (1/4")
- > External square drive according to DIN 3121 for machine-operated sockets
- > Also suitable for battery screwdrivers without impact effect

Code	No.	Hexagon	Hexagon	Hexagon	Hexagon	mm	kg
1834878	673 10	3/8"	10	1/4"	6,3	50	0,026
6536320	673 6,3	1/4"	6,3	1/4"	6,3	50	0,016

673 K

Adaptor
short pattern



- > External hexagon according to DIN 3126 - E 6.3 (1/4")
- > External square according to DIN 3120 - A 6.3 (1/4")

Code	No.	Hexagon	Hexagon	Hexagon	Hexagon	mm	kg
2000245	673 K	1/4"	6,3	1/4"	6,3	17	0,02

673 L

Adaptor
Long pattern



- > With external hexagon 1/4" and external square according to DIN 3120 - A 6.3 (1/4")
- > For hand operation
- > For use with driving handle, No. 676, or torque handle, No. 2140

Code	No.	Hexagon	Hexagon	Hexagon	Hexagon	mm	kg
1811061	673 L	1/4"	6,3	1/4"	6,3	130	0,05

676
Driving handle



- > Non-slip 2-component handle
- > With 1/4" hexagon socket

Code	No.	1/4"	6,3	kg
1649337	676	1/4"	6,3	0,042

699
Bit holder
for power tools



- > Acc. to DIN 7427 Form D
- > With hexagon drive as per DIN 3126 - E 6,3 (1/4")
- > With hexagon drive as per DIN 3126 - D 6,3 (1/4")
- > With magnetic holder

Code	No.	1/4"	6,3	1/4"	6,3	30	60	kg
6538610	699	1/4"	6,3	1/4"	6,3	30	60	0,023

699 L
Bit holder
Long pattern



- > With hexagon drive as per DIN 3126 - C 6,3 (1/4")
- > With hexagon drive as per DIN 3126 - D 6,3 (1/4")
- > For hand operation
- > With magnetic holder

Code	No.	1/4"	6,3	1/4"	6,3	32	130	kg
1802437	699 L	1/4"	6,3	1/4"	6,3	32	130	0,039

700
Bit holder
magnetic



- > With quick clamping system for bits with external hexagon drive according to DIN 3126 - C 6.3 (1/4") and E 6.3 (1/4")

Code	No.	1/4"	6,3	1/4"	6,3	14,0	60,5	kg
6530550	700	1/4"	6,3	1/4"	6,3	14,0	60,5	0,026

169
Magazine handle screwdriver



- > For heavy duty use
- > With 1/4" hexagonal socket
- > Magnetic magazine handle with room for 7 bits
- > Cap with click-locking

Code	No.	1/4"	6,3	Contents	115	220	kg
6432700	169	1/4"	6,3	Screwdriver bit 1/4" slot No. 680 4 5.5 6.5 Screwdriver bit 1/4" cross recess No. 690 PH 1 2 Screwdriver bit 1/4" cross recess No. 690 PZD 1 2	115	220	0,206

880
Screwdriver bit 5/16"
for slotted head screws

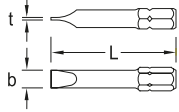

- > For hand operation and use in electric and air tools
- > Acc. to DIN ISO 2351-1
- > With hexagon drive as per DIN 3126 - C 8 (5/16")

Code	No.	⊖	t	L	
6566820	880 6,5	6.5	1,2	41	0,013
6567040	880 8	8	1,6	41	0,015
6567120	880 9	9	1,6	41	0,016
6567200	880 10	10	1,6	41	0,019
6567390	880 12	12	2	41	0,029
6567470	880 14	14	2,5	41	0,029

885
Screwdriver bit 5/16"
for in-hex screws

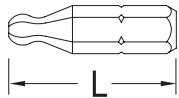

- > For hand operation and use in electric and air tools
- > Acc. to DIN ISO 2351-3
- > With hexagon drive as per DIN 3126 - C 8 (5/16")

Code	No.	●	ISO 4762	DIN 7984	L	
6568280	885 4	4	M5	M6	30	0,010
6568360	885 5	5	M6	M8	30	0,011
6568440	885 6	6	M8	M10	30	0,011
6568600	885 10	10	M12	M14	30	0,017

890
Screwdriver bit 5/16"
for cross-head screws PH

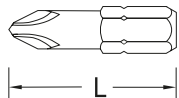

- > For hand operation and use in electric and air tools
- > Acc. to DIN ISO 2351-2, Tip according to DIN ISO 8764-1 PH
- > With hexagon drive as per DIN 3126 - C 8 (5/16")

Code	No.	⊕ PH	L	
6571580	890 1	1	32	0,010
6571660	890 2	2	32	0,010
6571740	890 3	3	32	0,010
6571820	890 4	4	32	0,012

890 PZD
Screwdriver bit 5/16"
for cross-head screws Pozi PZ

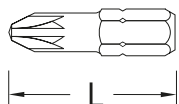

- > For hand operation and use in electric and air tools
- > Acc. to DIN ISO 2351-2, Tip according to DIN ISO 8764-1 PZ
- > With hexagon drive as per DIN 3126 - C 8 (5/16")

Code	No.	⊕ PZ	L	
6553250	890 PZD 1	1	32	0,009
6553330	890 PZD 2	2	32	0,010
6553410	890 PZD 3	3	32	0,011
6553760	890 PZD 4	4	32	0,013

885 X
Screwdriver bit 5/16"
for multi-point screws
XZN

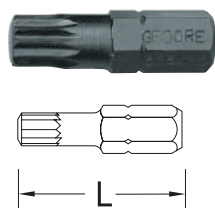

- > For hand operation and use in electric and air tools
- > With external hexagon drive to DIN 3126 - C 8 (5/16"), tip to DIN 2325

Code	No.	⊙	L	kg
6569250	885 X 6	M6	28	0,009
6569330	885 X 8	M8	28	0,011

887 TX
Screwdriver bit 5/16"
for recessed TX head
screws

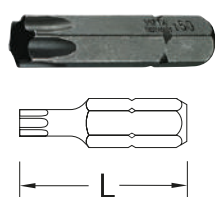

- > For hand operation and use in electric and air tools
- > With hexagon drive as per DIN 3126 - C 8 (5/16")

Code	No.	⊙	mm	L	kg
6571150	887 TX T30	T30	5,52	35	0,012
6571230	887 TX T40	T40	6,65	35	0,013
6571310	887 TX T45	T45	7,82	35	0,014
6575140	887 TX T50	T50	8,83	35	0,015

KB 819 - KB 830
Adaptor pieces for
screwdriver bits 5/16"

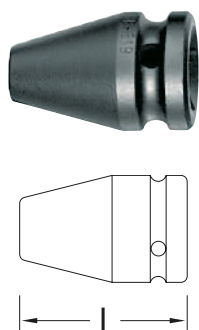

- > Acc. to DIN 7427 Form A
- > Hexagon socket according to DIN 3126 - D 6.3 (1/4")
- > Square drive Form G DIN 3121
- > For hand-operated or power tools
- > When using the machine, we recommend the use of a circlip and pin

Code	No.	⊙"	⊙mm	□"	□mm	↳ mm	kg
6563560	KB 820	5/16"	8,0	1/4"	6,3	25	0,018
6563800	KB 830	5/16"	8,0	3/8"	10	30	0,04
6563480	KB 819	5/16"	8,0	1/2"	12,5	35	0,075

871
Bit ratchet 5/16"



- > With knurled head for quick starting or counter-holding of screws
- > Hexagon socket according to DIN 3126 - D 8 (5/16")

> Slim line design for working in confined spaces

Code	No.	⊙"	⊙	∠°	↳ mm	mm	kg
6535430	871	5/16"	8	15°	127	20,2	0,1